

SEC. A-A

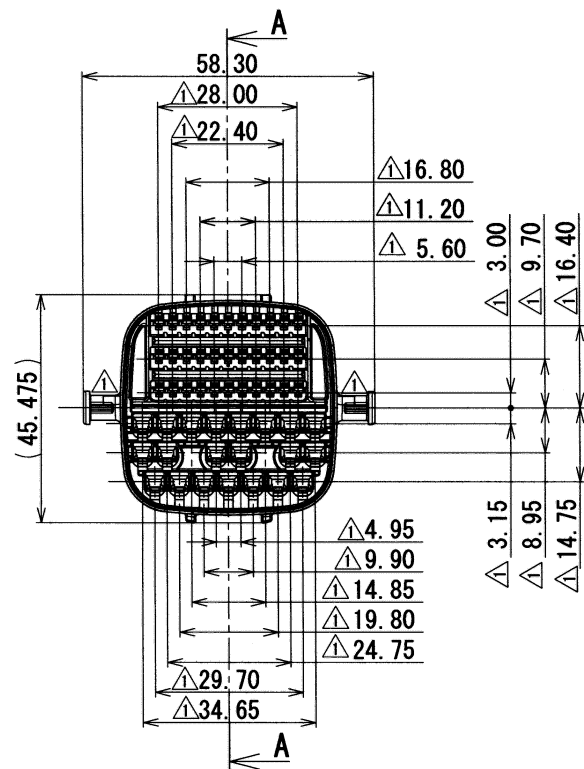
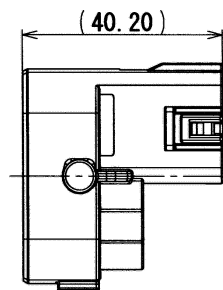

SUB ASSEMBLY PART NO. AND CH. CODE	NO.	PART NO. AND CH. CODE	MATERIAL	COLOR	QTY.
7283-8866-30, [A]	①	7183-8866-30	PBT	BLACK	1
	②	7158-3196-80	SILICONE RUBBER	RED IRON	1
	③	7158-5478-40	PBT	LIGHT GRAY	1

注記

- 嵌合相手品番 : 7282-8866-30
- 適用端子品番 : <RK>7116-1847-02 ETC. (AVSSH 0.3~0.5sq)  
<O90 II>7116-4025 ETC. (AVSSH 0.3~2.0sq)
- 適用ゴム栓品番 : <O90 II>7158-3003-90 ETC.
- 適用空栓品番 : <RK>7158-3197  
<O90 II>7158-3198-90
- 適用フロントホルダ品番 : 7158-5479

NOTES

- MATING PART NO. : 7282-8866-30
- APPLICABLE TERMINAL NO. : <RK>7116-1847-02 ETC. (AVSSH 0.3~0.5sq)  
<O90 II>7116-4025 ETC. (AVSSH 0.3~2.0sq)
- APPLICABLE SEAL RUBBER PART NO. : <O90 II>7158-3003-90 ETC.
- APPLICABLE RUBBER STOPPER PART NO. : <RK>7158-3197  
<O90 II>7158-3198-90
- APPLICABLE FRONT HOLDER PART NO. : 7158-5479

ISSUE MARK

				CUSTOMER				MATERIAL SPEC.				SEE TABLE		TREAT. & FIN.					
				CUSTOMER PART NO.				CUSTOMER DWG NO.				NAME 54P LIF SEALED CONNECTOR							
△ 04/12/21 CHANGED FORM, [A]				C04-ZF80 R. I								NAME 54P LIF SEALED CONNECTOR							
02/11/28 NEW				C02-X610 T. H								NAME 54P LIF SEALED CONNECTOR							
LET DATE REVISION RECORD				NO. CHKD				OFFICE TRIAL PART NO.				NAME 54P LIF SEALED CONNECTOR							
								VENDOR				NAME 54P LIF SEALED CONNECTOR							
								VENDOR NO.				NAME 54P LIF SEALED CONNECTOR							
GENERAL TOLERANCE								VENDOR NO.								NAME 54P LIF SEALED CONNECTOR			
	10MAX	50MAX	100MAX	250MAX	2500VR	ANGLE	ECCENT	DWG TYPE	DWG SOURCE	DWG DATE	UNIT	SCL	ANGLE	PART NO.	7283-8866-30, [A]				
A	±0.15	±0.2	±0.3	±0.5	±0.75	±30'	0.1	R	NEW	02/11/28	mm	1:1	3	CH. CODE	7283-8866-30, [A]				
B	±0.2	±0.3	±0.55	±0.95	±1.4	±30'	0.1	APPROVED	CHECKED	CHECKED	DESIGN	DRAWN		DWG NO.	7283-8866-30:R		SET DWG NO.		
©	±0.3	±0.5	±0.8	±1.4	±2	±30'	0.15	T. HAMAI		E. PANTONI		ROMEL GALIZA		YAZAKI CORPORATION					
SPECIFIED				MASS				g		04.12.23		04.12.23		04/12/23		02/05/13		04/12/21	