

1

2

3

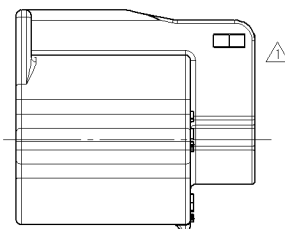
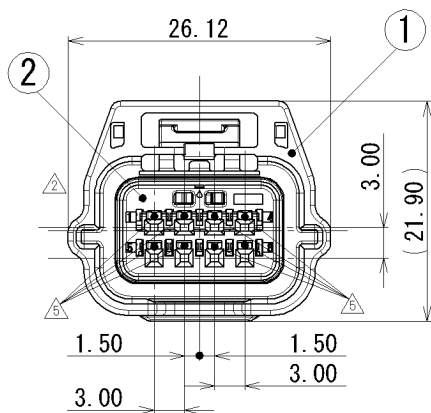
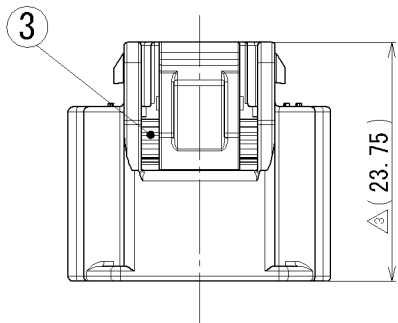

SUB ASSEMBLY PART NO. AND CH. CODE	NO.	PART NO. AND CH. CODE	△PART NAME	MATERIAL	COLOR	QTY.
7283-8855-30, D	①	7183-8855-30	HOUSING	PBT	BLACK	1
	②	△7158-5884	FRONT HOLDER	PBT	△NATURAL	1
	③	7137-2817-80	PACKING	SILICONE RUBBER	BROWN	1

注記

1. かん合相手品番 : 7282-8855-30
2. 適用端子品番 : 7116-4415-02 ETC.
- △ 3. 適用ゴム栓品番 : 7158-3165-90 ETC.
4. 適用防水栓品番 : 7158-3169-40

NOTES

1. MATING PART NO. : 7282-8855-30
2. APPLICABLE TERMINAL NO. : 7116-4415-02 ETC.
- △ 3. APPLICABLE RUBBER SEAL NO. : 7158-3165-90 ETC.
4. APPLICABLE UNUSED CAVITY PLUG: 7158-3169-40

△	10/10/15	CHANGED PART NAME	C10-ZA72	N. B
△	06/12/19	CHANGED FORM, ETC., D	C06-ZD52	Y. I
△	05/05/25	CHANGED FORM, C	C05-Z782	S. K
△	03/08/07	CHANGED CODE, B	C03-X324	T. Y
△	02/05/17	CHANGED FORM, A	C02-X538	T. Y
△	02/01/22	CHANGED FORM	C02-X160	T. Y
	01/11/08	NEW	C01-Y135	T. Y
LET	DATE	REVISION RECORD	NO.	CHKD

GENERAL TOLERANCE						
	10MAX	50MAX	100MAX	250MAX	2500VR	ANGLE
A	±0.15	±0.2	±0.3	±0.5	±0.75	±30°
B	±0.2	±0.3	±0.55	±0.95	±1.4	±30°
③	±0.3	±0.5	±0.8	±1.4	±2	±30°
SPECIFIED						MASS
						g

CUSTOMER		MATL. SPEC.		SEE TABLE		TREAT. & FIN.	
CUSTOMER PART NO.		CUSTOMER DWG NO.		NAME △6 RH TYPE HOUSING 8P			
OFFICE		TRIAL PART NO.		SUB ASSEMBLY FEMALE			
VENDOR		VENDOR NO.		PART NO. CH. CODE		7283-8855-30, D	
DWG TYPE		DWG SOURCE		DWG DATE		UNIT	
R		NEW		01/11/08		mm	
APPROVED		CHECKED		CHECKED		DESIGN	
S. MIZUSE		_____		R. CABANGAL		M. KASHIYAMA	
10/10/15		_____		10/10/15		01/04/28	
						DRAWN	
						N. BUSTARGA	
						DWG NO. 7283-8855-30:R	
						SET DWG NO.	
						YAZAKI CORPORATION	

ISSUE MARK

1

2

3