

△ 7283-9392-40 CODE B △ 7283-9393-10 CODE C △ 7283-0528-80 CODE D

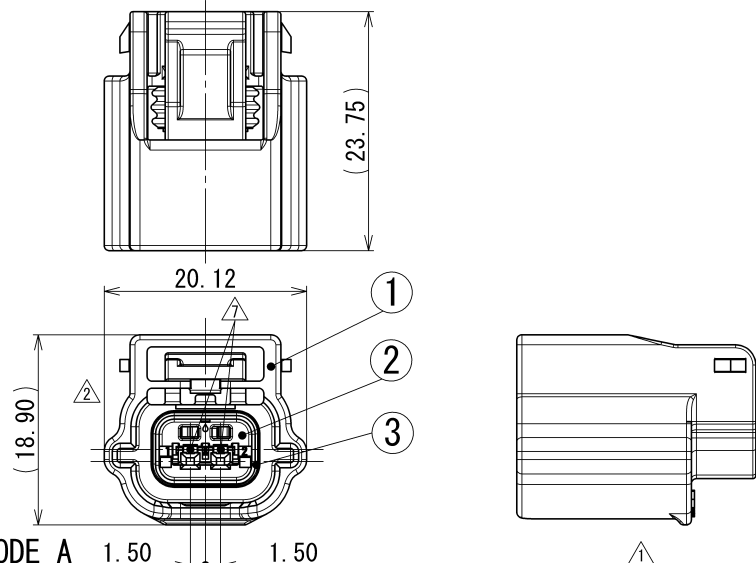

△ 7283-8851-30 CODE A 1.50 1.50

△	10/11/15	CHANGED PART NAME	C10-ZA90	G. M
△	06/10/12	CHANGED FORM, ETC. [D]	C06-Z201	Y. I
△	05/09/08	ADDED PART NO., CODE D	C05-ZC78	T. M
△	05/04/14	ADDED PART NO., CODE B, C	C05-Z549	S. K
△	04/06/17	CHANGED CODE, [C]	C04-Z633	H. Y
△	03/08/07	CHANGED CODE, [B]	C03-X324	T. Y
△	02/05/17	CHANGED FORM, [A]	C02-X538	T. Y
△	02/02/06	ELIMINATE SECTION	C02-X199	T. Y
△	01/11/08	NEW	C01-Y135	T. Y
LET	DATE	REVISION RECORD	NO.	CHKD

GENERAL TOLERANCE				
	10MAX	50MAX	100MAX	250MAX
A	±0.15	±0.2	±0.3	±0.5
B	±0.2	±0.3	±0.55	±0.95
③	±0.3	±0.5	±0.8	±1.4
SPECIFIED				MASS

CUSTOMER	CUSTOMER PART NO.	CUSTOMER DWG NO.
OFFICE	TRIAL PART NO.	
VENDOR	VENDOR NO.	
DWG TYPE	DWG SOURCE	DWG DATE
R	NEW	01/11/08
APPROVED	CHECKED	CHECKED
S. MIZUSE		R. CABANGAL
10/11/15		10/11/15
UNIT	SCL	ANGLE
mm	2:1	3
DESIGN	DRAWN	
M. KASHIYAMA	G. MAGNAYON	
01/05/08	10/11/15	

MATL. SPEC.	SEE TABLE	TREAT. & FIN.
NAME	△ RH TYPE HOUSING 2P	
	SUB ASSEMBLY FEMALE	
PART NO. CH. CODE	△ 7283-8851-30 ETC.	
DWG NO.	7283-8851-30:R	SET DWG NO.
	YAZAKI CORPORATION	

TABLE 1	SUB ASSEMBLY PART NO. AND CH. CODE	NO.	PART NO. AND CH. CODE	△ PART NAME	MATERIAL	COLOR	QTY.
	7283-8851-30 ETC.	①	SEE TABLE 2	HOUSING	PBT	SEE TABLE 2	1
		②	△ 7158-5262	FRONT HOLDER	PBT	△ 3. NATURAL	1
③		7137-2813-80	PACKING	SILICONE RUBBER	BROWN	1	

△ TABLE 2	SUB ASSEMBLY PART NO. AND CH. CODE	PART NO. AND CH. CODE	COLOR	MATING PART NO.
	7283-8851-30, [D]	7183-8851-30	BLACK	7282-8851-30
	△ 7283-9392-40, [A]	7183-9392-40	LIGHT GRAY	△ 7282-9392-40
	△ 7283-9393-10, [A]	7183-9393-10	DARK GRAY	△ 7282-9393-10
	△ 7283-0528-80, [A]	7183-0528-80	BROWN	7282-0528-80

注記

- 適用端子品番 : 7116-4415-02 ETC.
- 適用コネクタ品番 : 7158-3165-90, 7158-3166-60, 7158-3182-20
7158-3167-80, 7158-3168-80
- 適用防水栓品番 : 7158-3169-40

NOTES

- APPLICABLE TERMINAL NO. : 7116-4415-02 ETC.
- APPLICABLE SEAL RUBBER NO. : 7158-3165-90, 7158-3166-60, 7158-3182-20
7158-3167-80, 7158-3168-80
- APPLICABLE UNUSED CAVITY PLUG: 7158-3169-40