

SUB ASS'Y PART NO.	NO.	PART NO.	PART NAME	MATERIAL (COLOR)	△ QTY.
△ 7283-8648.△	①	7183-8648.△	A TYPE CONNECTOR HOUSING 24P (F)	PBT(NATURAL)	1
	②	7157-6774.△△	A TYPE CONNECTOR REAR HOLDER 24P (F)	PBT(NATURAL)	1

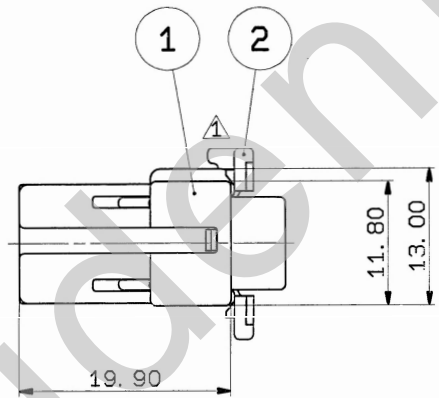
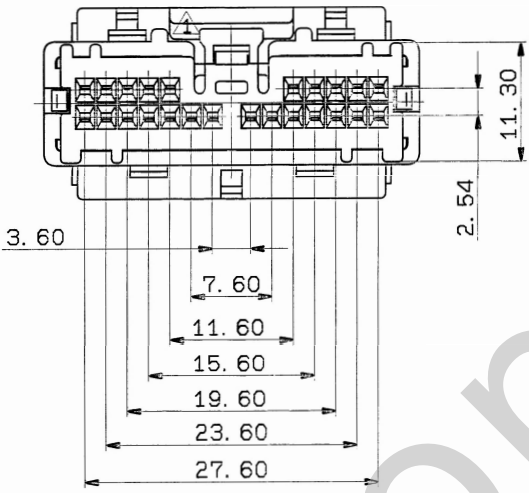
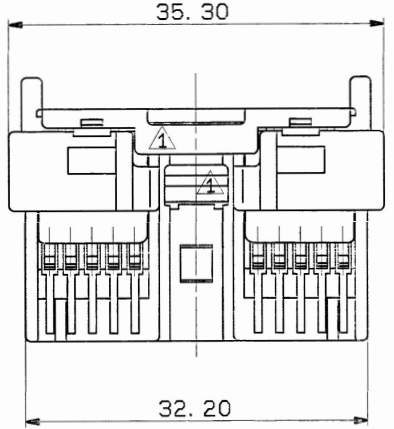

注 記

- 1. 嵌合相手は、7282-8648.
- △ 2. 使用ターミナルは、7116-1670-02.  
7116-1670-08.  
7116-1800-02.

NOTES

- 1. MATING PART NO. : 7282-8648.
- △ 2. APPLICABLE TERMINAL. : 7116-1670-02.  
7116-1670-08.  
7116-1800-02.

ISSUE MARK

△ 94. 11. 18	CH. REAR HOLDER COLOR	C94-M537	O. S	CUSTOMER	MATL. SPEC.	SEE TABLE	TREAT. & FIN.
△ 94. 06. 09	CHANGED FORM & CHANGED NOTE. △	C94-L711	O. S	CUSTOMER PART NO.	CUSTOMER DWG NO.	NAME A TYPE CONNECTOR 24P (F)	
90. 09. 17	NEW	C90-6982	H. Y	OFFICE	TRIAL PART NO.	SUB ASS'Y	
LET	DATE	REVISION RECORD NO.	CHKD	VENDOR	VENDOR NO.		
GENERAL TOLERANCE				DWG TYPE	DWG SOURCE	DWG DATE	UNIT
	10MAX	50MAX	100MAX	250MAX	250OVR	ANGLE	ECCENT
A	±0. 15	±0. 2	±0. 3	±0. 5	±0. 75	±30'	0. 1
B	±0. 2	±0. 3	±0. 55	±0. 95	±1. 4	±30'	0. 1
◎	±0. 3	±0. 5	±0. 8	±1. 4	±2	±30'	0. 15
SPECIFIED				APPROVED	CHECKED	CHECKED	DESIGN
MASS				11 木	74. 11. 24	H. SAITOH	SATOH
g				74. 4. 25	94. 11. 24	90. 09. 17	94. 11. 18
PART NO.						7283-8648. △	
CH. CODE						7283-8648: R	
DWG NO.						7283-8648: R	
YAZAKI CORPORATION							