

SEC. A-A

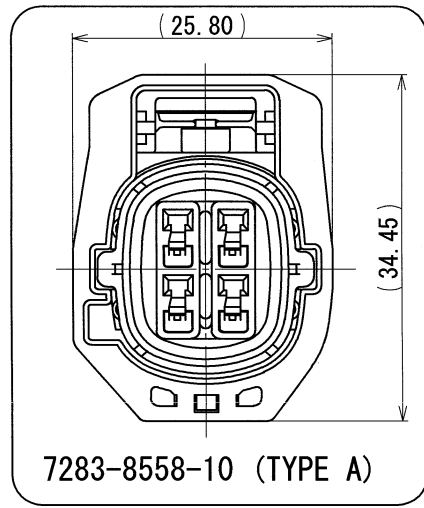

TABLE 1

SUB ASSEMBLY PART NO. AND CH. CODE	NO.	PART NO. AND CH. CODE	MATERIAL	COLOR	QTY.
7283-8559-30 ETC.	①	SEE TABLE 2	PBT	SEE TABLE 2	1
	②	7137-2714-50	SILICONE RUBBER	RED	1

TABLE 2

SUB ASSEMBLY PART NO. AND CH. CODE	PART NO. AND CH. CODE	COLOR
7283-8558-10	7183-8558-10	DARK GRAY
7283-8559-30	7183-8559-30	BLACK

注記

- 嵌合相手品番 : 7182-8559-30 ETC.
- 適用端子品番 : 7116-4102-02 ETC.

NOTES

- MATING PART NO. : 7182-8559-30 ETC.
- APPLICABLE TERMINAL NO. : 7116-4102-02 ETC.

GENERAL TOLERANCE

	10 MAX	50 MAX	100 MAX	250 MAX	250 OVR	R5 MAX	R10 MAX	R20 MAX	R20 OVR	ANGLE	ECCENT
A	±0.15	±0.2	±0.3	±0.5	±0.75					±3°	0.1
B	±0.2	±0.3	±0.55	±0.95	±1.4	±0.2	±0.3	±0.5	±2.5	±3°	0.1
(C)	±0.3	±0.5	±0.8	±1.4	±2					±3°	0.15

				CUSTOMER				MATL. SPEC. SEE TABLE 1				TREAT. & FIN.			
				CUSTOMER PART NO.				CUSTOMER DWG NO.							
02/10/31				NEW				C02-Y295				K. Y			
LET				DATE				REVISION RECORD				NO. CHKD			
								OFFICE				TRIAL PART NO.			
								VENDOR							
								VENDOR NO.							
				GENERAL TOLERANCE				DWG TYPE				DWG SOURCE			
								R				NEW			
								APPROVED				CHECKED			
								K. YOSHIDA				Y. IMAI			
SPECIFIED				MASS				02.11.07				02.11.05			
								DESIGN				DRAWN			
								02/03/14				02/10/31			
								PART NO. 7283-8559-30 ETC.				CH. CODE			
								DWG NO. 7283-8559-30:R				SET DWG NO.			
								YAZAKI CORPORATION							