

1 2 3

TABLE 1

SUB ASSEMBLY PART NO. AND CH. CODE	NO.	PART NO. AND CH. CODE	MATERIAL	COLOR	△ QTY.
7283-8226 ETC.	①	SEE TABLE 2	PBT	SEE TABLE 2	1
	②	7157-4427	PBT	NATURAL	1
	③	SEE TABLE 2	PBT	SEE TABLE 2	1
	④	7137-2609-80	SILICONE RUBBER	DARK BROWN	1

△ TABLE 2

SUB ASSEMBLY PART NO. AND CH. CODE	HOUSING PART NO. AND CH. CODE	PACKING HOLDER PART NO. AND CH. CODE	COLOR
7283-8226.□	7183-8226	7157-4235	NATURAL
7283-8226-30.□	7183-8226-30	7157-4235-30	BLACK
7283-8226-40.□	7183-8226-40	7157-4235-40	LIGHT GRAY
7283-8226-80.□	7183-8226-80	7157-4235-80	BROWN

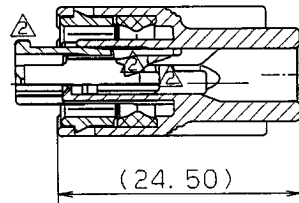
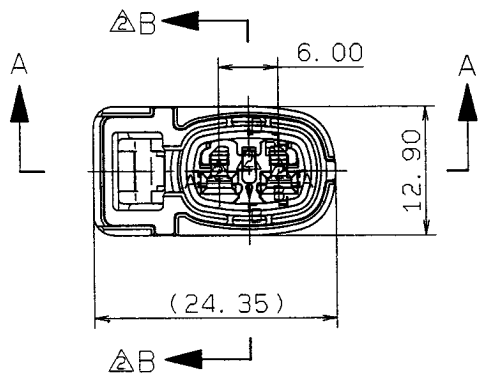

SEC. B-B

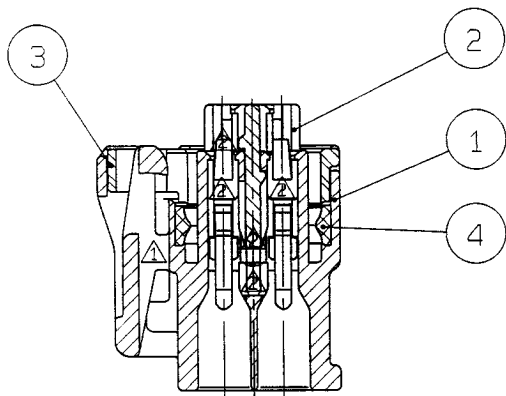

SEC. A-A

注記

△ 1. 適用端子品番：090II 7116-4025 ETC.

NOTE

△ 1. APPLICABLE TERMINAL NO. :
090II 7116-4025 ETC.

ISSUE MARK

△ 99.02.03	ELIMINATED COLOR NO. CHANGED FORM & NOTE. □	C99-L188	S. S	CUSTOMER		MATL. SPEC. SEE TABLE 1	TREAT. & FIN.
△ 96.06.14	CHANGED FORM. △	C96-M115	A. Y	CUSTOMER PART NO.	CUSTOMER DWG NO.	NAME 090II 2P SEALED CONNECTOR	
93.04.13	NEW	C93-L442	H. F	OFFICE	TRIAL PART NO.	HOUSING FEMALE SUB ASSEMBLY	
LET	DATE	REVISION RECORD NO.	CHKD	VENDOR			
GENERAL TOLERANCE				VENDOR NO.			
	10MAX	50MAX	100MAX	250MAX	2500VR	ANGLE	ECCENT
A	±0.15	±0.2	±0.3	±0.5	±0.75	±30'	0.1
B	±0.2	±0.3	±0.55	±0.95	±1.4	±30'	0.1
(C)	±0.3	±0.5	±0.8	±1.4	±2	±30'	0.15
SPECIFIED				MASS	g		
				99.02.09	99.02.09	99.02.09	99.02.03
				加藤	川梨	福輪	YAMAMOTO HIRATA
				90.04.02			
				YAZAKI CORPORATION			

1 2 3