

TABLE 1

YAZAKI SUB ASSEMBLY PART NO.	NO.	YAZAKI PART NO.	MATERIAL	COLOR	△QTY.
7283-7644 ETC.	①	SEE TABLE 2	△ HPA	SEE TABLE 2	1
	②	7157-4578	△ HPA	NATURAL	1

TABLE 2

YAZAKI SUB ASSEMBLY PART NO.	YAZAKI PART NO.	COLOR
7283-7644, △	7183-7644	NATURAL
7283-7644-10, △	7183-7644-10	DARK GRAY
7283-7644-30, △	7183-7644-30	BLACK
7283-7644-40, △	7183-7644-40	LIGHT GRAY
7283-7644-50, △	7183-7644-50	ORANGE
7283-7644-60, △	7183-7644-60	GREEN
7283-7644-80, △	7183-7644-80	BROWN
7283-7644-90, △	7183-7644-90	BLUE

B

B

A

A

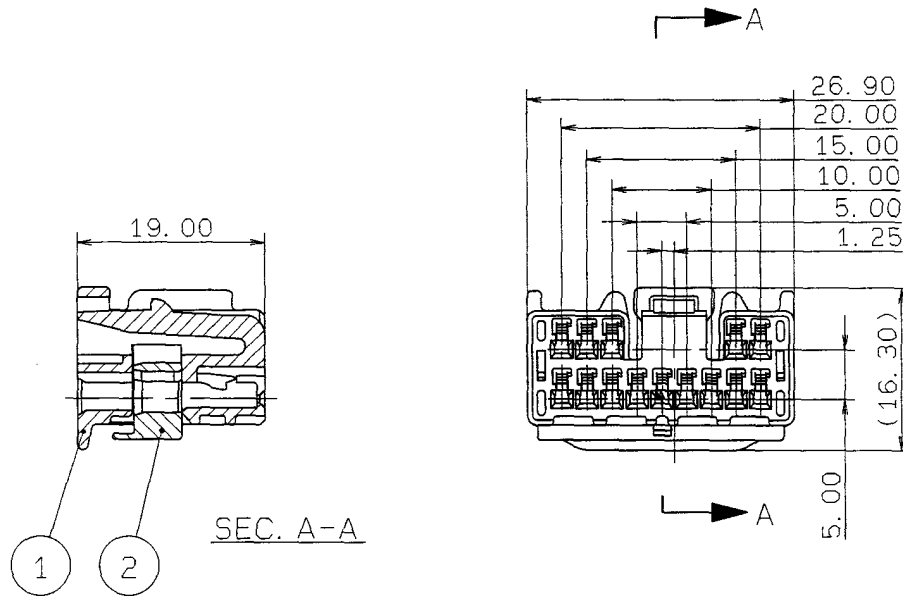

注記

1. 適用端子品番: 7116-1257 ETC.

NOTE

1. APPLICABLE TERMINAL PART NO.: 7116-1257 ETC.

ISSUE MARK

				CUSTOMER				MATL. SPEC.				SEE TABLE 1				TREAT. & FIN.																																							
△ 97.07.15				CHANGED MATERIAL. △				C97-M497				H. K				CUSTOMER PART NO.				CUSTOMER DWG NO.																																			
93.03.17				NEW				C93-L324				H. F				OFFICE				TRIAL PART NO.																																			
LET				DATE				REVISION RECORD				NO.				CHKD				VENDOR																																			
GENERAL TOLERANCE								VENDOR NO.								NAME																																							
10MAX		50MAX		100MAX		250MAX		250OVR		ANGLE		ECCENT		DWG TYPE		DWG SOURCE		DWG DATE		UNIT		SCL		ANGLE		PART NO.																													
A ±0.15		±0.2		±0.3		±0.5		±0.75		±30°		0.1		R		NEW		93.03.17		mm		2/1		3		7283-7644 ETC.																													
B ±0.2		±0.3		±0.55		±0.95		±1.4		±30°		0.1		APPROVED		CHECKED		CHECKED		DESIGN		DRAWN		DWG NO.																															
© ±0.3		±0.5		±0.8		±1.4		±2		±30°		0.15		加藤		山梨		田中		T. MIWA		ITO H		7283-7644:R																															
SPECIFIED								MASS								YAZAKI CORPORATION																																							
								9								97.07.24								97.07.21								97.07.18								92.04.21								97.07.15							

