

1

2

3

## GENERAL TOLERANCE

	10 MAX	50 MAX	100 MAX	250 MAX	250 OVR	R5 MAX	R10 MAX	R20 MAX	R20 OVR	ANGLE	ECCENT
A	±0.15	±0.2	±0.3	±0.5	±0.75	±0.2	±0.3	±0.5	±2.5	±3°	0.1
B	±0.2	±0.3	±0.55	±0.95	±1.4					±3°	0.1
◎	±0.3	±0.5	±0.8	±1.4	±2					±3°	0.15

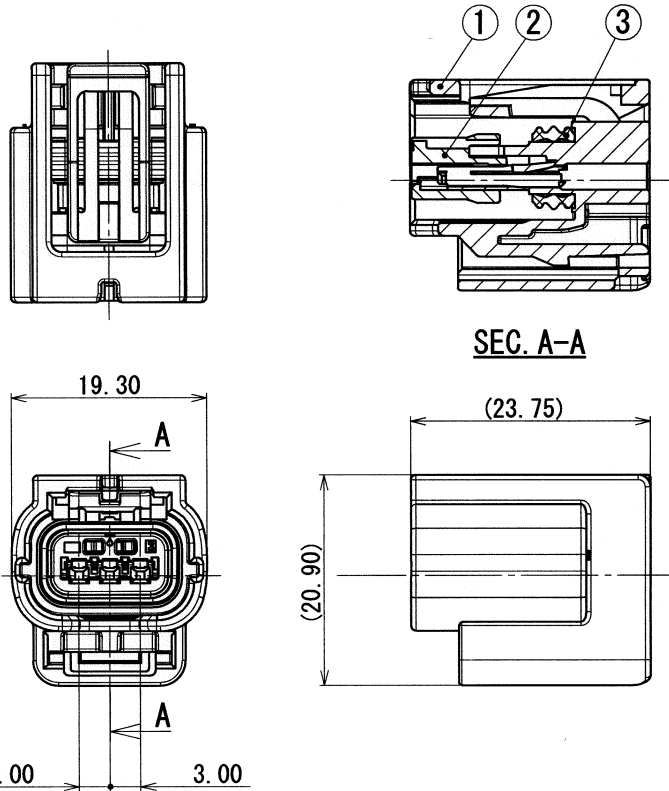

TABLE 1

SUB ASSEMBLY PART NO. AND CH. CODE	NO.	PART NO. AND CH. CODE	MATERIAL	COLOR	QTY.
△7283-2147-30 ETC.	①	△SEE TABLE 2	PBT	△SEE TABLE 2	1
	②	7158-6347	PBT-G	NATURAL	1
	③	7137-2842-80	SILICONE RUBBER	BROWN	1

TABLE 2

SUB ASSEMBLY PART NO. AND CH. CODE	PART NO. AND CH. CODE	COLOR
△7283-2147	7183-2147	NATURAL
7283-2147-30	7183-2147-30	BLACK
△7283-2147-40	7183-2147-40	LIGHT GRAY

## 注記

- △ 1. 嵌合相手品番 : 7282-2147-30 ETC.  
 2. 適用端子品番 : 7116-4415-02 ETC.  
 3. 適用ゴム栓品番 : 7158-3165-90 ETC.  
 4. 適用防水栓品番 : 7158-3169-40

## NOTES

- △ 1. MATING PART NO. : 7282-2147-30 ETC.  
 2. APPLICABLE TERMINAL NO. : 7116-4415-02 ETC.  
 3. APPLICABLE SEAL RUBBER NO. : 7158-3165-90 ETC.  
 4. APPLICABLE UNUSED CAVITY PLUG: 7158-3169-40

ISSUE MARK

△	05/08/31	ADDED PART NO.	C05-ZC17	K. N	CUSTOMER	MATL. SPEC.	SEE TABLE 1	TREAT. & FIN.							
△	05/02/28	ADDED PART NO., ETC.	C05-Z343	K. N	CUSTOMER PART NO.	CUSTOMER DWG NO.									
	04/02/19	NEW	C04-X159	K. N	OFFICE	TRIAL PART NO.									
LET	DATE	REVISION RECORD	NO.	CHKD	VENDOR										
GENERAL TOLERANCE					VENDOR NO.										
	10MAX	50MAX	100MAX	250MAX	250OVR	ANGLE	ECCENT	DWG TYPE	DWG SOURCE	DWG DATE	UNIT	SCL	ANGLE	PART NO. CH. CODE	△ 7283-2147-30 ETC.
A	±0.15	±0.2	±0.3	±0.5	±0.75	±30'	0.1	R	NEW	04/02/19	mm	2:1	3	DWG NO.	7283-2147-30:R
B	±0.2	±0.3	±0.55	±0.95	±1.4	±30'	0.1	APPROVED	CHECKED	CHECKED	DESIGN	DRAWN	SET DWG NO.		
C	±0.3	±0.5	±0.8	±1.4	±2	±30'	0.15	<i>Y. Yokohashi</i> <i>K. Niho</i> <i>S. Mitorai</i> 05.09.06 05.09.06 05.09.06		K. NIIHO	E. PANTONI				
SPECIFIED					MASS	g					03/08/25		05/08/31	YAZAKI CORPORATION	

1

2

3