

SEC. A-A

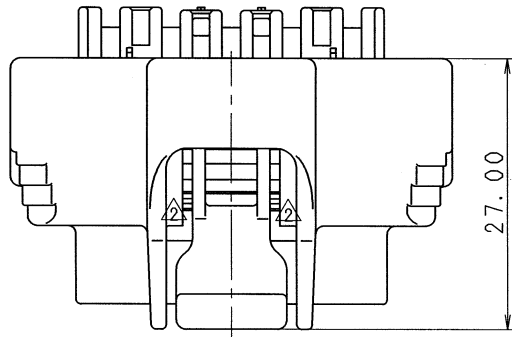

TABLE 1	SUB ASSEMBLY PART NO. AND CH. CODE	NO.	PART NO. AND CH. CODE	MATERIAL	COLOR	QTY.
	△7283-1057-30 ETC.	①	SEE TABLE 2	PBT	SEE TABLE 2	1
		②	7157-4364	PBT	NATURAL	1
		③	△7137-2241-60	△SILICONE RUBBER	△LIGHT GREEN	1

△ TABLE 2	SUB ASSEMBLY PART NO. AND CH. CODE	PART NO. AND CH. CODE	COLOR
	7283-1057.□	7183-1057	NATURAL
	7283-1057-30.□	7183-1057-30	BLACK
△	7283-1057-40.□	7183-1057-40	LIGHT GRAY

注記

1. 適用端子番:090Ⅱ 7116-4025 ETC.

NOTE

1. APPLICABLE TERMINAL NO.
:090Ⅱ 7116-4025 ETC.

△	00.11.20	ADDED COLOR NO.	C00-M513	C. T					ISSUE MARK	
△	99.07.09	ELIMINATED COLOR NO. , CHANGED FORM. MATERIAL, PART NO. & COLOR. □	C99-M110	C. T	CUSTOMER		MATERIAL SPEC.		TREAT. & FIN.	
△	97.05.08	CHANGED FORM. □	C97-L770	H. K	CUSTOMER PART NO.		CUSTOMER DWG NO.		NAME	
	93.03.19	NEW	C93-L377	I. I	OFFICE		TRIAL PART NO.		090Ⅱ 5P SEALED CONNECTOR	
LET	DATE	REVISION RECORD	NO.	CHKD	VENDOR		VENDOR NO.		HOUSING FEMALE SUB ASSEMBLY	
GENERAL TOLERANCE					DWG TYPE	DWG SOURCE	DWG DATE	UNIT	SCL	ANGLE
	10MAX	50MAX	100MAX	250MAX	250QVR	ANGLE	ECCENT			
A	±0.15	±0.2	±0.3	±0.5	±0.75	±30'	0.1	R	NEW	93.03.19
B	±0.2	±0.3	±0.55	±0.95	±1.4	±30'	0.1	APPROVED	CHECKED	CHECKED
(C)	±0.3	±0.5	±0.8	±1.4	±2	±30'	0.15	加藤	山梨	鳥居
SPECIFIED					MASS	g	00.11.30	00.11.30	00.11.28	89.05.16
										00.11.20
							PART NO. △ 7283-1057-30 ETC.		CH. CODE	
							DWG NO. 7283-1057:R		SET DWG NO.	
							YAZAKI CORPORATION			