

SEC. A-A

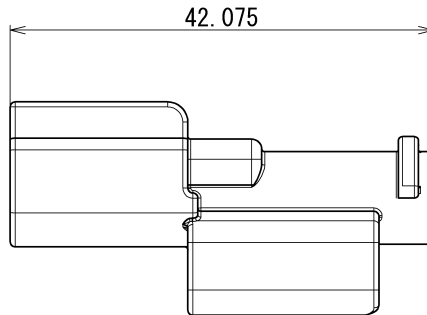
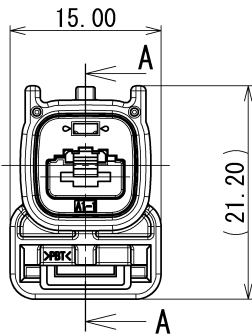

△ TABLE 1

SUB ASSEMBLY PART NO. AND CH. CODE	NO.	PART NO. AND CH. CODE	△ PART NAME	MATERIAL	COLOR	QTY.
△ 7282-9285-30 ETC.	①	△ SEE TABLE 2	187 1P SEALED HOUSING MALE	PBT	△ SEE TABLE 2	1
	②	7158-6711	187 1P SEALED FRONT HOLDER MALE	PBT	NATURAL	1

△ TABLE 2

SUB ASSEMBLY PART NO. AND CH. CODE	PART NO. AND CH. CODE	COLOR
7282-9285	7182-9285	NATURAL
7282-9285-30	7182-9285-30	BLACK

注記

- △ 1. かん合相手品番 : 7283-9285-30, 7283-9285
- 2. 適用端子品番 : 7114-4035, 7114-4036, 7114-4037
- 3. 適用ゴム栓品番 : 7158-3014-90, 7158-3015-10  
7158-3016-80, 7158-3017

NOTES

- △ 1. MATING PART NO. : 7283-9285-30, 7283-9285
- 2. APPLICABLE TERMINAL NO. : 7114-4035, 7114-4036, 7114-4037
- 3. APPLICABLE RUBBER SEAL NO. : 7158-3014-90, 7158-3015-10  
7158-3016-80, 7158-3017

GENERAL TOLERANCE												ECCENT	ISSUE MARK
	10 MAX	50 MAX	100 MAX	250 MAX	250 OVR	R5 MAX	R10 MAX	R20 MAX	R20 OVR	ANGLE			
A	±0.15	±0.2	±0.3	±0.5	±0.75					±3°	0.1		
B	±0.2	±0.3	±0.55	±0.95	±1.4	±0.2	±0.3	±0.5	±2.5	±3°	0.1		
◎	±0.3	±0.5	±0.8	±1.4	±2					±3°	0.15		

CUSTOMER					MATERIAL SPEC.					TREAT. & FIN.				
△	DATE	REVISION RECORD	NO.	CHKD	CUSTOMER PART NO.	CUSTOMER DWG NO.	NAME	PART NO. CH. CODE			SET DWG NO.			
	10/10/21	ADDED COLOR PART NO. ETC.	C10-Z619	M.S			SEE TABLE 1							
	05/03/16	NEW	C05-Z479	H.O			△ 187 1P SEALED HOUSING							
LET	DATE	REVISION RECORD	NO.	CHKD	OFFICE	TRIAL PART NO.	SUB ASSEMBLY MALE							
GENERAL TOLERANCE					VENDOR NO.					PART NO. CH. CODE				
A	±0.15	±0.2	±0.3	±0.5	±0.75	±30°	0.1	DWG TYPE	DWG SOURCE	DWG DATE	UNIT	SCL	ANGLE	△ 7282-9285-30 ETC.
B	±0.2	±0.3	±0.55	±0.95	±1.4	±30°	0.1	R	NEW	05/03/16	mm	2:1	3	
C	±0.3	±0.5	±0.8	±1.4	±2	±30°	0.15	APPROVED	CHECKED	CHECKED	DESIGN	DRAWN	DWG NO.	7282-9285-30:R
SPECIFIED	MASS				N. SUGIE	T. MATSUNAGA	M. SUZUKI	M. SUZUKI	M. MALABANAN	YAZAKI CORPORATION				
					10/10/21	10/10/21	10/10/21	04/11/01	10/10/21					