

SEC. A-A

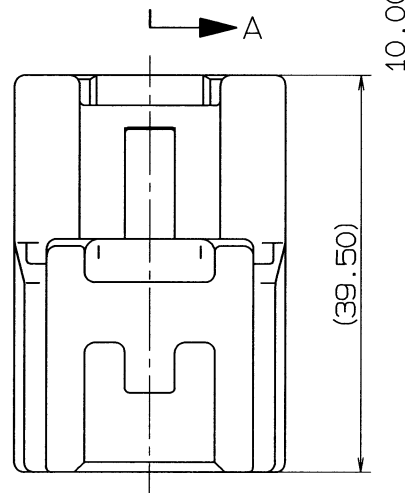
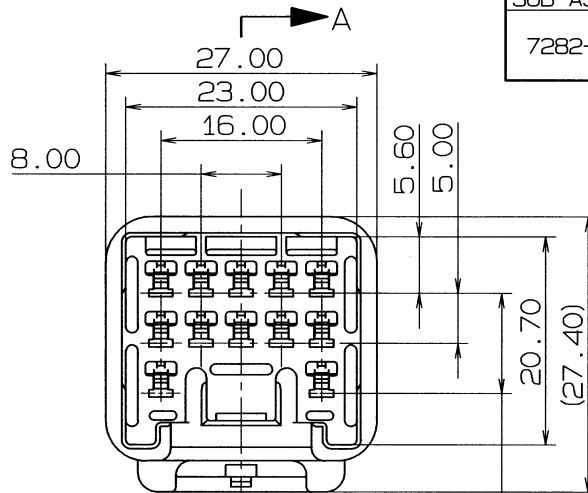

TABLE 1

YAZAKI SUB ASSEMBLY PART NO.	NO.	YAZAKI PART NO.	MATERIAL	COLOR	QTY.
7282-4325 ETC.	①	SEE TABLE 2	△ HPA	SEE TABLE 2	1
	②	7157-4537	△ HPA	NATURAL	1

TABLE 2

YAZAKI SUB ASSEMBLY PART NO.	YAZAKI PART NO.	COLOR
7282-4325 , ▢	7182-4325	NATURAL
7282-4325-10, ▢	7182-4325-10	DARK GRAY
7282-4325-30, ▢	7182-4325-30	BLACK
7282-4325-40, ▢	7182-4325-40	LIGHT GRAY
7282-4325-50, ▢	7182-4325-50	ORANGE
7282-4325-60, ▢	7182-4325-60	GREEN
7282-4325-80, ▢	7182-4325-80	BROWN
7282-4325-90, ▢	7182-4325-90	BLUE

注記

1. 嵌合端子品番 : 7283-4325 ETC.

2. 適用端子品番 : 7114-4020 ETC.

NOTES

1. MATING PART NO.: 7283-4325 ETC.

2. APPLICABLE TERMINAL NO.: 7114-4020 ETC.

ISSUE MARK

					CUSTOMER					MATERIAL SPEC.			TREAT. & FIN.			
					CUSTOMER PART NO.					CUSTOMER DWG NO.						
△ 96.07.01 CHANGED MATERIAL, ▢ C96-M109 A.Y 93.05.14 NEW C93-L529 H.F					OFFICE					TRIAL PART NO.			NAME			
LET DATE REVISION RECORD NO. CHKD					VENDOR					VENDOR NO.			NEW 090 II 12P CONNECTOR			
GENERAL TOLERANCE										PART NO.			HOUSING MALE SUB ASSEMBLY			
	10MAX	50MAX	100MAX	250MAX	2500VR	ANGLE	ECCENT	DWG TYPE	DWG SOURCE	DWG DATE	UNIT	SCL	ANGLE	7282-4325 ETC.		
A	±0.15	±0.2	±0.3	±0.5	±0.75	±30'	0.1	R	NEW	93.05.14	mm	2/1	3	CH.CODE		
B	±0.2	±0.3	±0.55	±0.95	±1.4	±30'	0.1	APPROVED	CHECKED	CHECKED	DESIGN	DRAWN		7282-4325: R		
©	±0.3	±0.5	±0.8	±1.4	±2	±30'	0.15	〆 〆 96.07.04		96.07.04	T.UEDA	S.UJIBO		DWG NO.		
SPECIFIED					MASS					91.11.05			96.07.01		YAZAKI CORPORATION	