

SEC. A-A

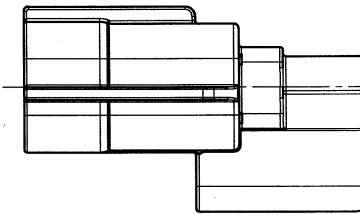
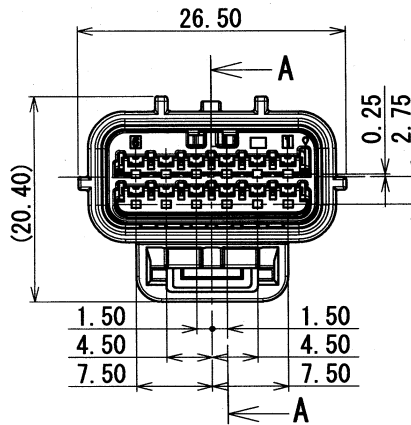

TABLE 1	SUB ASSEMBLY PART NO. AND CH. CODE	NO.	PART NO. AND CH. CODE	MATERIAL	COLOR	QTY.
	△7282-4038-30 ETC.	①	SEE TABLE 2 △	PBT	SEE TABLE 2 △	1
		②	7158-6586	PBT-G	NATURAL	1

TABLE 2	SUB ASSEMBLY PART NO. AND CH. CODE	PART NO. AND CH. CODE	COLOR
	7282-4038-30	7182-4038-30	BLACK
△	7282-4038-40	7182-4038-40	LIGHT GRAY

NOTES

- △ 1. MATING PART NO. : 7283-4038-30 ETC.
- 2. APPLICABLE TERMINAL NO. : 7114-4415-02, 7114-4416-02, 7114-4417-02
- 3. APPLICABLE SEAL RUBBER NO. : 7158-3165-90, 7158-3166-60, 7158-3167-80, 7158-3168-80
- 4. APPLICABLE UNUSED CAVITY PLUG: 7158-3169-40

注記

- △ 1. 嵌合相手品番 : 7283-4038-30 ETC.
- 2. 適用端子品番 : 7114-4415-02, 7114-4416-02, 7114-4417-02
- 3. 適用ゴム栓品番 : 7158-3165-90, 7158-3166-60, 7158-3167-80, 7158-3168-80
- 4. 適用防水栓品番 : 7158-3169-40

ISSUE MARK

△		05/05/16	ADDED PART NO., ETC.	C05-Z719	K. N	CUSTOMER		CUSTOMER PART NO.			CUSTOMER DWG NO.			MATL. SPEC.		SEE TABLE 1		TREAT. & FIN.	
		04/02/27	NEW	C04-X160	K. N	OFFICE		TRIAL PART NO.					NAME		HS 025 12P SEALED CONNECTOR				
LET		DATE	REVISION RECORD	NO.	CHKD	VENDOR		VENDOR NO.					NAME		SUB ASSEMBLY MALE				
		GENERAL TOLERANCE			VENDOR NO.							PART NO. CH. CODE		△ 7282-4038-30 ETC.					
A	10MAX	50MAX	100MAX	250MAX	2500VR	ANGLE	ECCENT	DWG TYPE	DWG SOURCE	DWG DATE	UNIT	SCL	ANGLE	DWG NO.		7282-4038-30:R		SET DWG NO.	
B	±0.15	±0.2	±0.3	±0.5	±0.75	±30'	0.1	R	NEW	04/02/27	mm	2:1	3						
③	±0.2	±0.3	±0.55	±0.95	±1.4	±30'	0.1	APPROVED	CHECKED	CHECKED	DESIGN	DRAWN							
③	±0.3	±0.5	±0.8	±1.4	±2	±30'	0.15	<i>K. Niiho</i>	<i>K. Niiho</i>	<i>S. Mitorai</i>	K. NIIHO	J. GAVILANGA							
SPECIFIED		MASS			g			05.05.20		05.05.19		05.05.19		03/12/24		05/05/16		YAZAKI CORPORATION	