

TABLE 1

SUB ASSEMBLY PART NO. AND CH. CODE	NO.	PART NO. AND CH. CODE	MATERIAL	COLOR	QTY.
7282-3030 ETC.	①	SEE TABLE 2	△ PBT	SEE TABLE 2	1
	②	7157-4444	△ PBT	NATURAL	1

△ TABLE 2

SUB ASSEMBLY PART NO. AND CH. CODE	PART NO. AND CH. CODE	COLOR
7282-3030. □	7182-3030	NATURAL
7282-3030-30. □	7182-3030-30	BLACK
7282-3030-40. □	7182-3030-40	LIGHT GRAY
7282-3030-70. □	7182-3030-70	YELLOW
7282-3030-90. □	7182-3030-90	BLUE

注記

- 1. 嵌合相手品番 : 7283-3030 ETC.
- 2. 適用端子品番 : 7114-6041 ETC.

NOTES

- 1. MATING PART NO. : 7283-3030 ETC.
- 2. APPLICABLE TERMINAL NO. : 7114-6041 ETC.

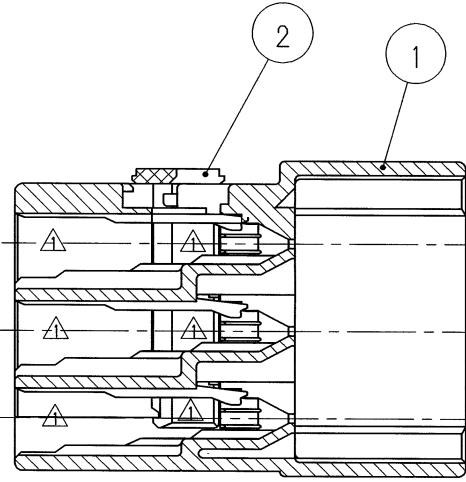

SEC. A-A

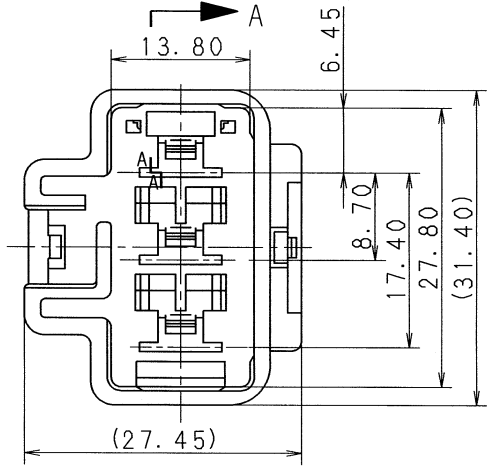

△	00.11.20	ELIMINATED COLOR NO. . ADDED COLOR NO. & CHANGED MATERIAL. □	C00-M512	Y. S							ISSUE MARK
△	96.07.02	CHANGED FORM & CHANGED MATERIAL. □	C96-M163	H. K	CUSTOMER		MATERIAL SPEC.		TREAT. & FIN.		
	92.07.17	NEW	C92-L525	A. H	CUSTOMER PART NO.		SEE TABLE 1				
LET	DATE	REVISION RECORD	NO.	CHKD	OFFICE		TRIAL PART NO.		NAME		
					VENDOR				312 3P CONNECTOR		
					VENDOR NO.				SUB ASSEMBLY MALE		
GENERAL TOLERANCE					DWG TYPE	DWG SOURCE	DWG DATE	UNIT	SCL	ANGLE	PART NO. CH. CODE
	10MAX	50MAX	100MAX	250MAX	250QVR	ANGLE	ECCENT				7282-3030 ETC.
A	±0.15	±0.2	±0.3	±0.5	±0.75	±30'	0.1	R	NEW	92.06.24	mm
B	±0.2	±0.3	±0.55	±0.95	±1.4	±30'	0.1	APPROVED	CHECKED	CHECKED	DESIGN
③	±0.3	±0.5	±0.8	±1.4	±2	±30'	0.15				DRAWN
SPECIFIED				MASS	g	加藤	山梨	杉山	KITAGAWA	Y. HATORI	DWG NO.
						00.11.30	00.11.30	00.11.23	90.09.12	00.11.20	7282-3030:R
										SET DWG NO.	
											YAZAKI CORPORATION

