

SUB-ASSEMBLY PART NUMBER	NO.	PART NUMBER	PART NAME	MATERIAL	COLOR	QUANTITY
7282-2432-30	①	7182-2432-30	12P 1.5 YESC REDUCED PITCH SEALED MALE HOUSING	PBT-GF15	BLACK	1
	②	7158-6170	12P 1.5 YESC REDUCED PITCH SEALED MALE TPA	PBT-GF15	NATURAL	1

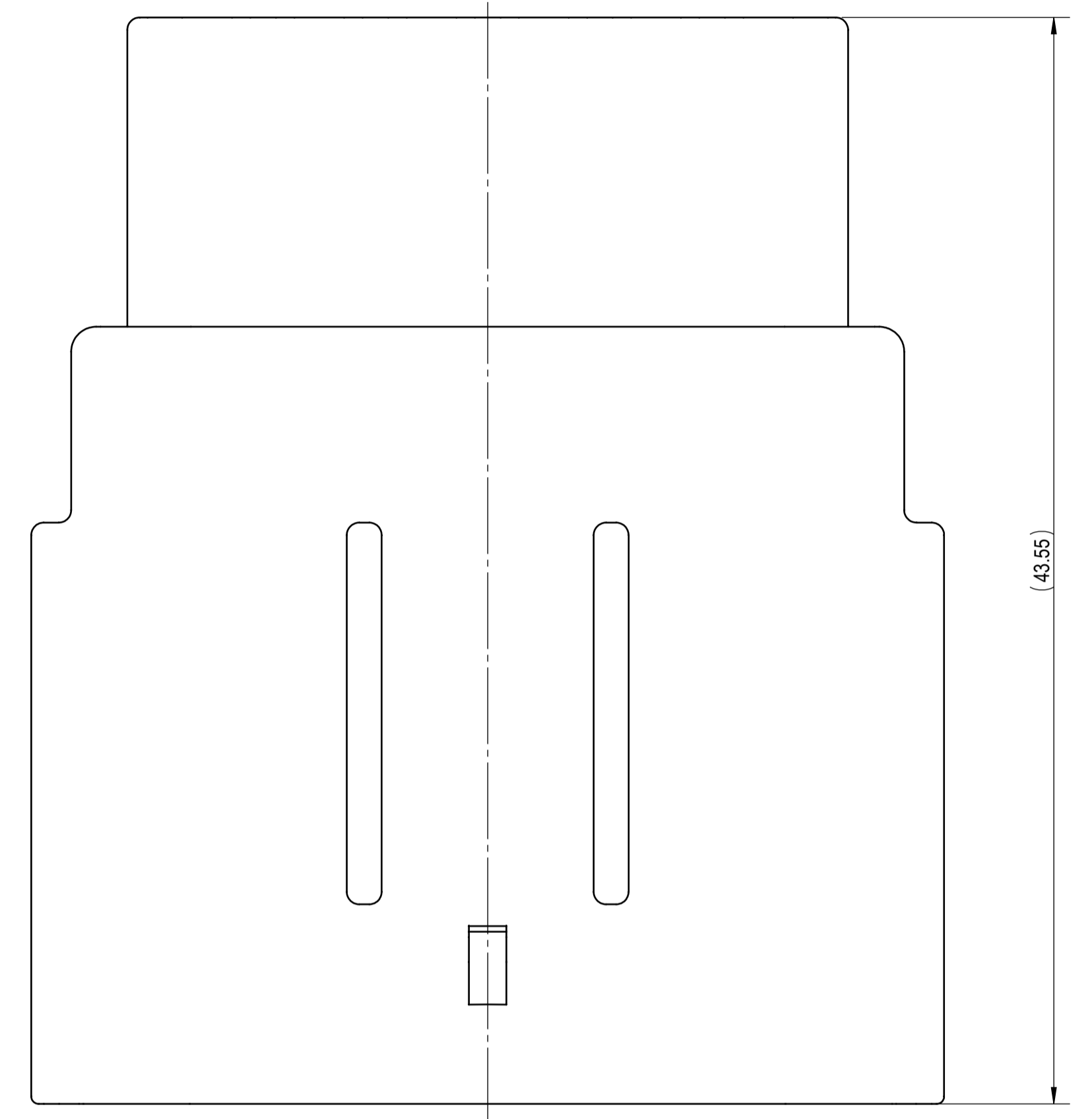

NOTES:

- PARTS MUST BE PURCHASED FROM YAZAKI.
- PARTS MUST BE FREE OF FLASH AND IMPERFECTIONS THAT AFFECT FUNCTION.
- APPLICABLE TERMINAL: SEE 7114-4102-02:R DRAWING (1.5 YESC SEALED TIN PLATED)  
MAX WIRE OD: 2.40mm  
MIN WIRE OD: 1.10mm  
SEE 7114-4102-06:R DRAWING (1.5 YESC SEALED SILVER PLATED)  
MAX WIRE OD: 2.40mm  
MIN WIRE OD: 1.10mm  
SEE 7114-4102-08:R DRAWING (1.5 YESC SEALED GOLD PLATED)  
MAX WIRE OD: 2.40mm  
MIN WIRE OD: 1.10mm
- APPLICABLE WIRE SEAL: SEE 7158-3374-90:R DRAWING (1.5 REDUCED PITCH SEALED)
- APPLICABLE CAVITY PLUG: SEE 7158-3037-70:R DRAWING (1.5 REDUCED PITCH SEALED)
- MATING PART NUMBER: 7283-2432-30, ETC.
- PART SATISFIES USCAR-2, REVISION 3, DATED APRIL 2001, (T3/V2/S2) WITH THE FOLLOWING EXCEPTIONS:  
5.4.2. CONNECTOR TO CONNECTOR ENGAGE FORCE = 76N MAX.
- PART TO COMPLY WITH YPES-31-038 REQUIREMENTS.
- THIS DIMENSION SHOWS THE PRE-SET POSITION OF THE TPA.
- THIS DRAWING IS TO BE USED FOR INTERNAL YAZAKI PSW SUBMISSION.
- HANDLING MANUAL NUMBER: YPES-15-1227E

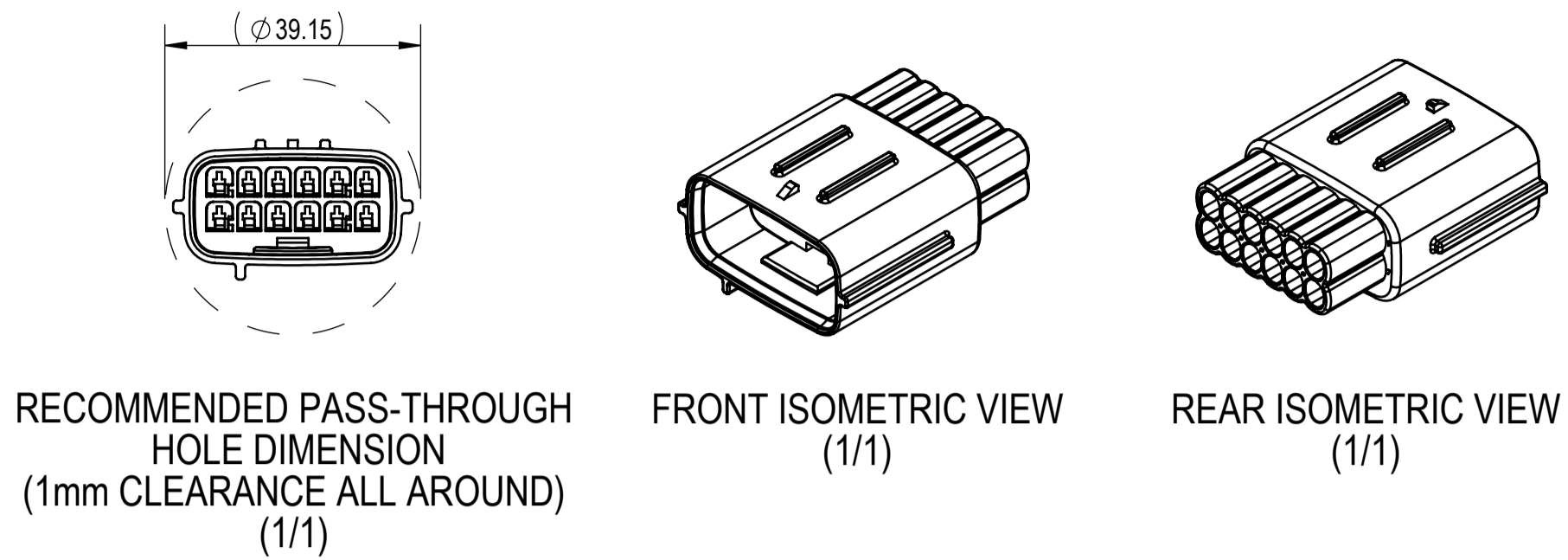
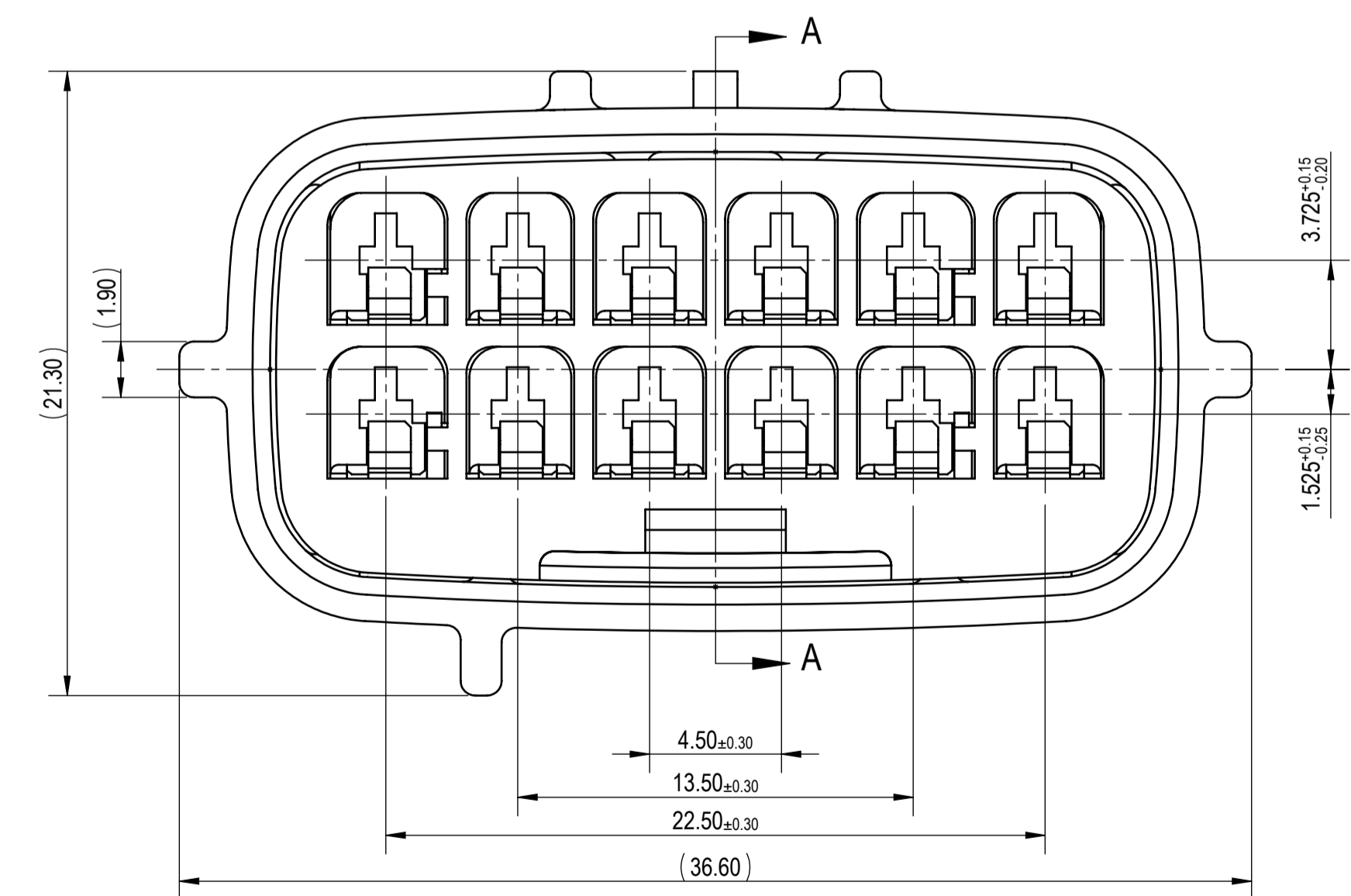
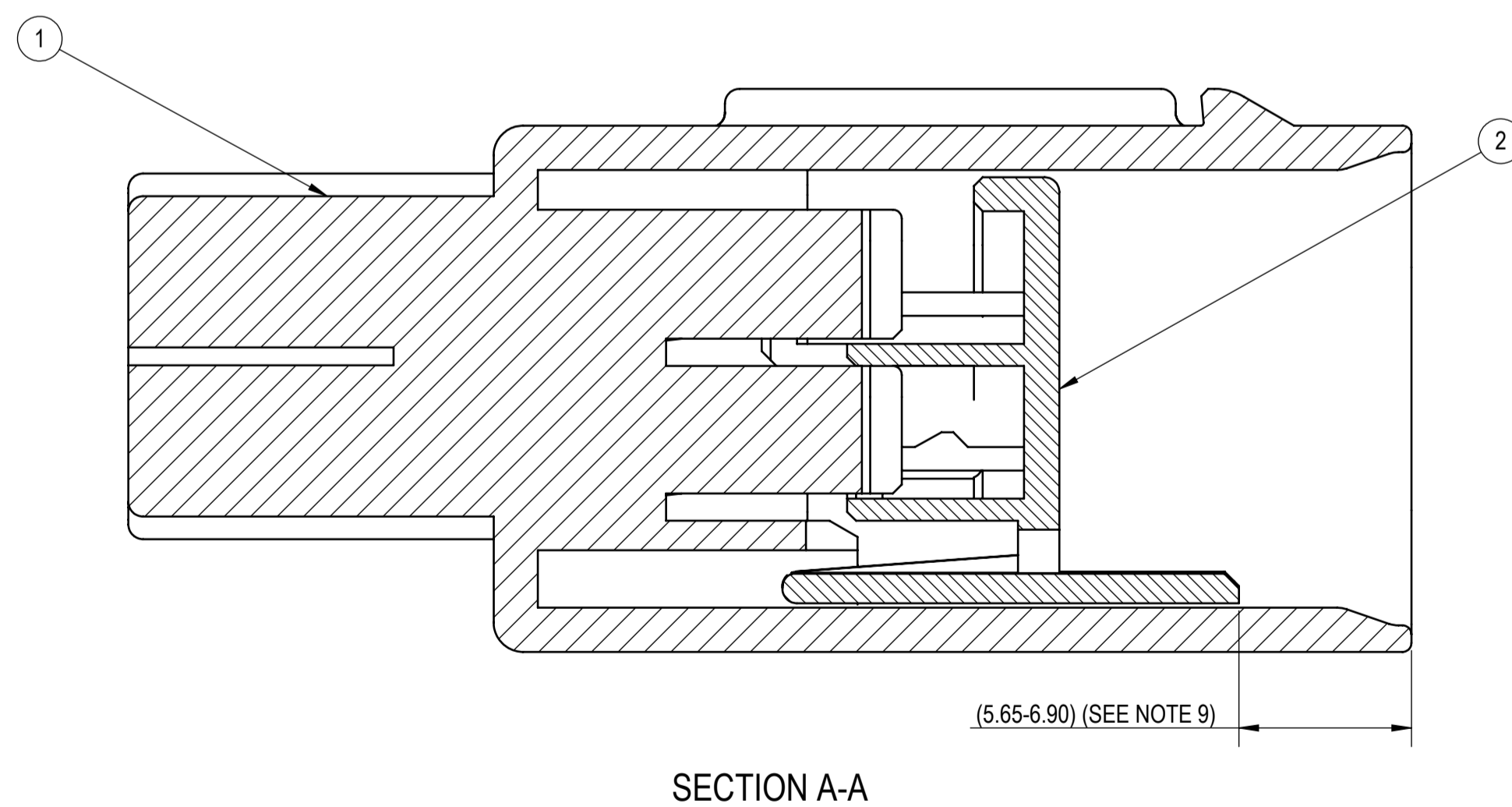
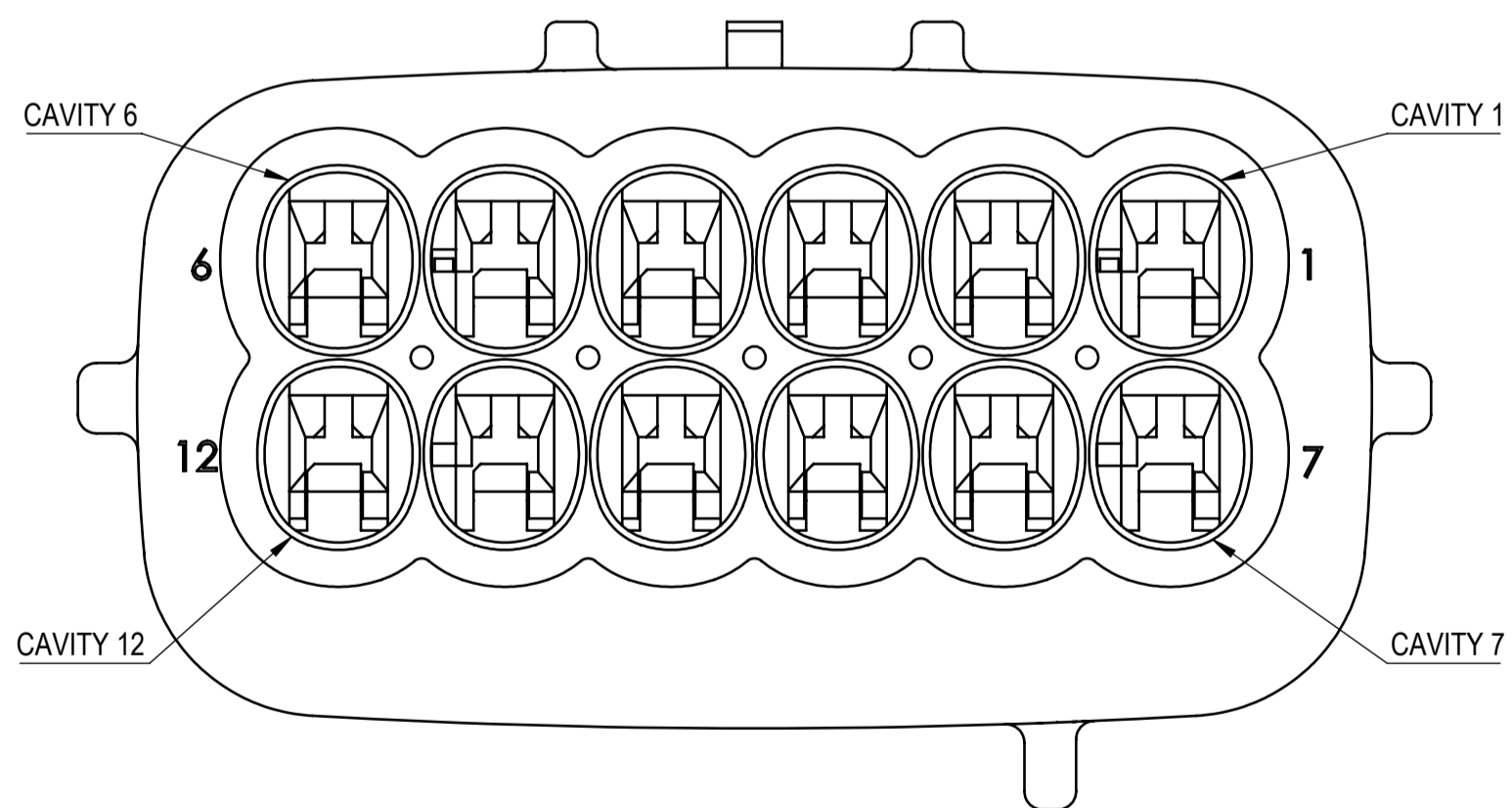

LET	DATE	REVISION RECORD	NO.	CHKD
-	12-07-2017	NEW	C17-AC46	A.C.

GENERAL TOLERANCE										
A	±0.15	±0.20	±0.30	±0.50	±0.75	±0.20	±0.30	±0.50	±2.50	±3°
B	±0.20	±0.30	±0.55	±0.95	±1.40	±0.20	±0.30	±0.50	±2.50	±3°
C	±0.30	±0.50	±0.80	±1.40	±2.00	±0.20	±0.30	±0.50	±2.50	±3°
SPECIFIED										
MASS (13.00)g										

CUSTOMER		CUSTOMER DWG. NO.		MTRL SPEC.		TREAT. & FIN.	
CUSTOMER PART NO.		CUSTOMER DWG. NO.		SEE TABLE		N/A	
OFFICE YNA		TRIAL PART NO.		NAME 12P 1.5 YESC REDUCED PITCH			
VENDOR		VENDOR NO.		SEALED MALE CONNECTOR SUB-ASSEMBLY			
DWG TYPE R		DWG SOURCE 7282-2432-30:M		DWG DATE 12-07-2017		UNIT mm	
APPROVED		CHECKED		CHECKED		DESIGN TONY HUYNH	
DRAWN		DRAWN		DRAWN		DRAWN ALEJANDRO CALLEROS	
DATE 05-17-2002		DATE 02-26-2018		PART NO. 7282-2432-30		CH. CODE	
				DWG NO. 7282-2432-30:R		YAZAKI CORPORATION	

ISSUE MARK