

SUB ASSEMBLY PART NO. AND CH. CODE	NO.	PART NO. AND CH. CODE	MATERIAL	COLOR	QTY.
7283-1927-30, [A]	①	7183-1927-30	PBT	BLACK	1
	③	7137-2195-80	SILICONE RUBBER	BROWN △	1
7283-1928-80, [A]	②	7183-1928-80	PBT	BROWN	1
	③	7137-2195-80	SILICONE RUBBER	BROWN △	1

注記

1. 適用リアホルダ品番 : 7157-6826-80
2. 適用端子品番 : 7116-1236, 7116-1237
3. 適用ゴム栓品番 : 7157-3560, 7157-3561-80
- △ 4. 適用バルブ : 7283-1927-30...#9005 (HB3)バルブ用  
: 7283-1928-80...#9006 (HB4)バルブ用

NOTES

1. APPLICABLE REAR HOLDER NO. : 7157-6826-80
2. APPLICABLE TERMINAL NO. : 7116-1236, 7116-1237
3. APPLICABLE RUBBER SEAL NO. : 7157-3560, 7157-3561-80
- △ 4. APPLICABLE BULB : 7283-1927-30...BULB FOR #9005 (HB3)  
: 7283-1928-80...BULB FOR #9006 (HB4)

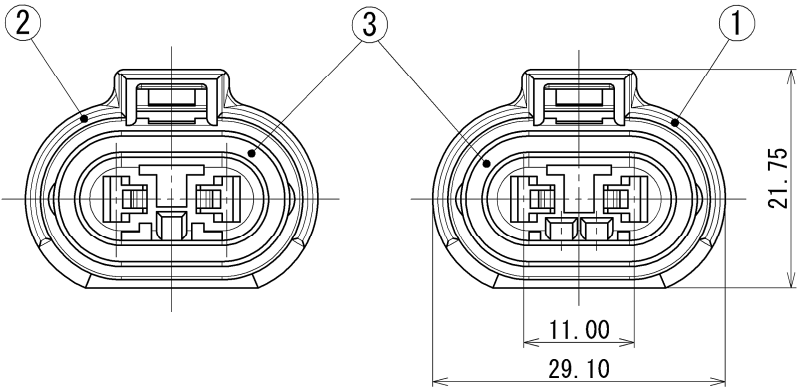

7283-1928-80

7283-1927-30

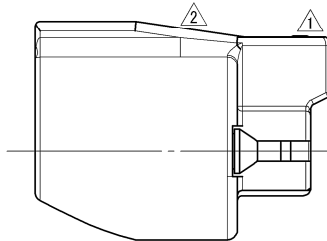

ISSUE MARK

△ 2014/10/09	ADDED NOTES	C14-Y120	K. U	CUSTOMER	MATL. SPEC.	SEE TABLE	TREAT. & FIN.	
△ 2000/12/16	CHANGED FORM	C00-M616	Y. S	CUSTOMER PART NO.	CUSTOMER DWG NO.	NAME HEAD LAMP CONNECTOR		
△ 1999/07/21	CHANGED FORM ETC., [A]	C99-M176	Y. S	OFFICE	TRIAL PART NO.	SUB ASSEMBLY		
1993/10/21	NEW	C93-M148	H. K	VENDOR	VENDOR NO.	PART NO. 7283-1927-30 ETC.		
LET	DATE	REVISION RECORD NO.	CHKD	DWG NO. 7283-1927-30:R				SET DWG NO.
GENERAL TOLERANCE				PART NO. 7283-1927-30 ETC.				YAZAKI CORPORATION
A	±0.15	±0.2	±0.3	±0.5	±0.75	±30'	0.1	
B	±0.2	±0.3	±0.55	±0.95	±1.4	±30'	0.1	
C	±0.3	±0.5	±0.8	±1.4	±2	±30'	0.15	
SPECIFIED				MASS	T. YAMAWAKI	K. URANO	YASHIMA	M. AKIYAMA
					2014/10/09	2014/10/09	1988/11/23	2014/10/09