

NO.	PART NO.	NAME	MATERIAL	COLOR
①	7123-1823-30	W TYPE CONNECTOR HOUSING 2PF(B)	NYLON	BLACK
②	7137-2320-80	PACKING FOR W TYPE CONNECTOR 2P	SELF LUBRICATING SILICON RUBBER	BROWN

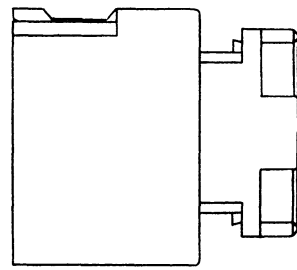
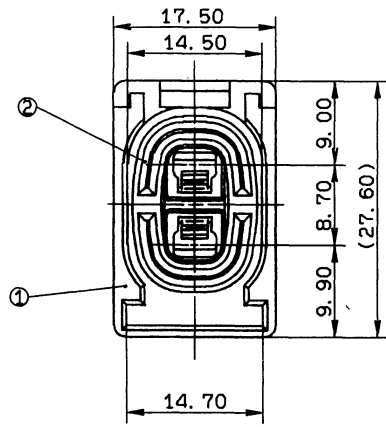
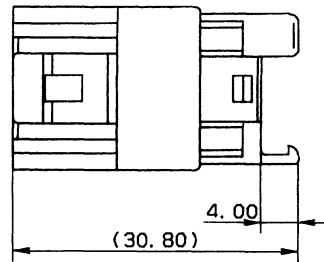

NOTES

- 1) APPLICABLE TERMINAL NO. :  
7116-1232 ETC.
- 2) APPLICABLE REAR HOLDER NO. :  
7157-6520-80
- 3) MATING PART NO. :7122-1823-30

注記

- 1) 適用端子品番:7116-1232 ETC.
- 2) 適用リヤホルダ`品番:7157-6520-80
- 3) 嵌合相手品番:7122-1823-30

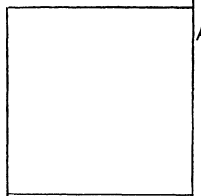

										CUSTOMER		MATERIAL SPEC.		TREAT. & FIN.	
										CUSTOMER PART NO.		SEE TABLE			
										CUSTOMER DWG NO.		NAME		W TYPE CONNECTOR 2PF(B)	
										OFFICE		STDLIB NO.			
										VENDOR		VENDOR NO.			
GENERAL TOLERANCE										PART NO.		7223-1823-30			
10MAX	50MAX	100MAX	250MAX	2500VR	ANGLE	ECCENT	DWG TYPE	DWG SOURCE	DWG DATE	UNIT.	SCL	ANGLE			
A ±0.15	±0.2	±0.3	±0.5	±0.75	±30'	0.1	SR	NEW	88.10.20	mm	2/1	3			
B ±0.2	±0.3	±0.55	±0.95	±1.4	±30'	0.1	APPROVED	CHECKED	CHECKED	DESIGN	DRAWN				
© ±0.3	±0.5	±0.8	±1.4	±2	±30'	0.15			SAKAI		S. YAGI		DWG NO. 7223-1823-30:R		
SPECIFIED						WEIGHT	g		85.06.28		88.10.20		YAZAKI CORPORATION		

1

2

3

