

SUB ASSEMBLY PART NO. AND CH. CODE	NO.	PART NO. AND CH. CODE	MATERIAL	COLOR
7222-6244-40, Δ	①	7122-6244-40	PBT	GRAY
	②	7137-2440-80	SILICONE RUBBER	BROWN

注記

- 嵌合雌ハウジング品番: 7123-6244-40
- 適用ターミナル品番: 7114-2873, -2874
- 適用ゴム栓品番: 7157-3570, -3571-80

NOTES

- APPLICABLE FEMALE HOUSING PART NO. : 7123-6244-40
- APPLICABLE TERMINAL PART NO. : 7114-2873, -2874
- APPLICABLE RUBBER SEAL NO. : 7157-3570, -3571-80

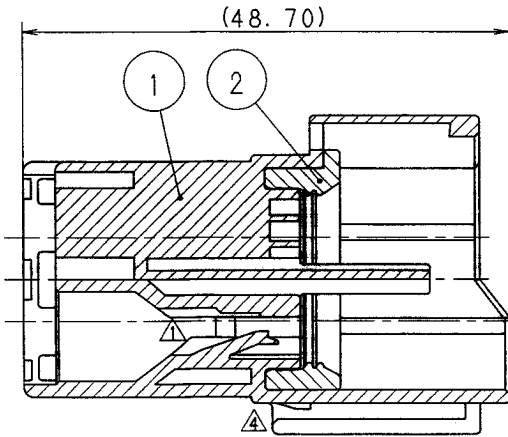

SEC. A-A

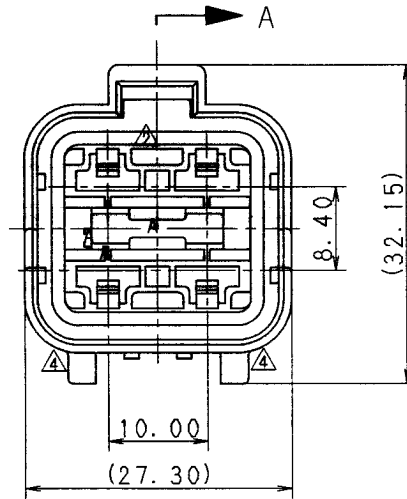

A

DATE	REVISION RECORD	NO.	CHKD	CUSTOMER	CUSTOMER PART NO.	CUSTOMER DWG NO.	MATL. SPEC.	SEE TABLE	TREAT. & FIN.					
00.02.15	CHANGED FORM. Δ	C00-L211	M. K											
94.06.29	CORRECTION OF A CLERICAL ERROR	C94-L901	M. T											
90.10.16	CORRECTED AN ERROR IN WRITING	C90-7296	H. Y											
88.04.21	CHANGED FORM	8MC-4050	T. M											
87.11.12	NEW	7MC-4118	T. M											
LET	DATE	REVISION RECORD	NO.	CHKD	VENDOR	TRIAL PART NO.	NAME X TYPE CONNECTOR							
GENERAL TOLERANCE				VENDOR NO.	SUB ASSEMBLY 4PM (GY) Δ									
A	±0.15	±0.2	±0.3	±0.5	±0.75	±30'	0.1	DWG TYPE R	DWG SOURCE NEW	DWG DATE 87.11.12	UNIT mm	SCL 2/1	ANGLE 3	PART NO. CH. CODE 7222-6244-40, Δ
B	±0.2	±0.3	±0.55	±0.95	±1.4	±30'	0.1	APPROVED	CHECKED	CHECKED	DESIGN	DRAWN	DWG NO. 7222-6244-40:R	SET DWG NO.
(C)	±0.3	±0.5	±0.8	±1.4	±2	±30'	0.15				T. MASUDA	T. YOSHIDA		
SPECIFIED				MASS	g	00.03.09	00.03.07	00.03.07	87.11.12	00.02.15	YAZAKI CORPORATION			