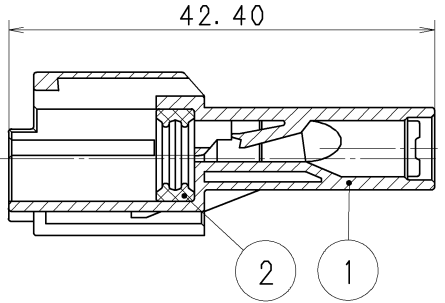
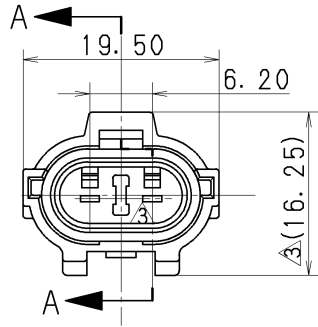

TABLE 1	SUB ASSEMBLY PART NO. AND CH. CODE	NO.	PART NO. AND CH. CODE	PART NAME	MATERIAL	COLOR	QTY.
7222-1424-40 ETC.		①	SEE TABLE 2	MALE HOUSING	PBT	SEE TABLE 2	1
		②	7137-1550-80	LIP PACKING	SILICONE RUBBER	RED-IRON	1



SEC. A-A

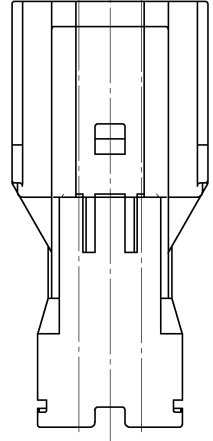
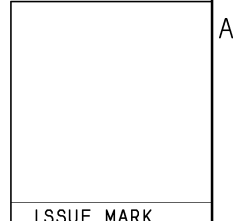

TABLE 2	SUB ASSEMBLY PART NO. AND CH. CODE	PART NO. AND CH. CODE	COLOR
7222-1424	7122-1424	NATURAL	
7222-1424-30	7122-1424-30	BLACK	
7222-1424-40	7122-1424-40	GRAY	

NOTE
1. MATING PART NO. : 7123-1424-40 ETC.

注記
1. 対応相手品番 : 7123-1424-40 ETC.



					CUSTOMER					MATERIAL SPEC. SEE TABLE 1			TREAT. & FIN.					
					CUSTOMER PART NO.					CUSTOMER DWG NO.								
③ 09.06.02 CHANGED TABLE, ETC. C09-Z410 T. K					OFFICE					NAME SWP-TYPE CONNECTOR								
② 93.12.20 CHANGED FORM & RENEW C93-L829 K. S					VENDOR					SUB ASS'Y 2P M								
LET	DATE	REVISION RECORD			NO.	CHKD	VENDOR NO.					PART NO. 7222-1424-40 ETC.						
GENERAL TOLERANCE							DWG TYPE	DWG SOURCE	DWG DATE	UNIT	SCL	ANGLE	DWG NO. 7222-1424-30 : R					
	10MAX	50MAX	100MAX	250MAX	2500VR	ANGLE	ECCENT	R	RENEW	93.12.20	mm	2/1	3	YAZAKI CORPORATION				
A	±0.15	±0.2	±0.3	±0.5	±0.75	±30'	0.1	APPROVED	CHECKED	CHECKED	DESIGN	DRAWN						
B	±0.2	±0.3	±0.55	±0.95	±1.4	±30'	0.1	N. SUGIYAMA		T. KOBAYASHI	KODAMA	R. BUCE						
③	±0.3	±0.5	±0.8	±1.4	±2	±30'	0.15	09.06.02		09.06.02	88.01.23	09.06.02						
SPECIFIED							MASS											

