

PART NUMBER	COLOR	MATERIAL	DIMENSION A (mm)	WIRE O.D. (mm)
7158-3376-50	ORANGE	SILICONE	0.55	1.1-1.4
7158-3374-90	TURQUOISE	SILICONE	0.95	1.4-1.9
7158-3375-80	LT. BROWN	SILICONE	1.55	1.8-2.4

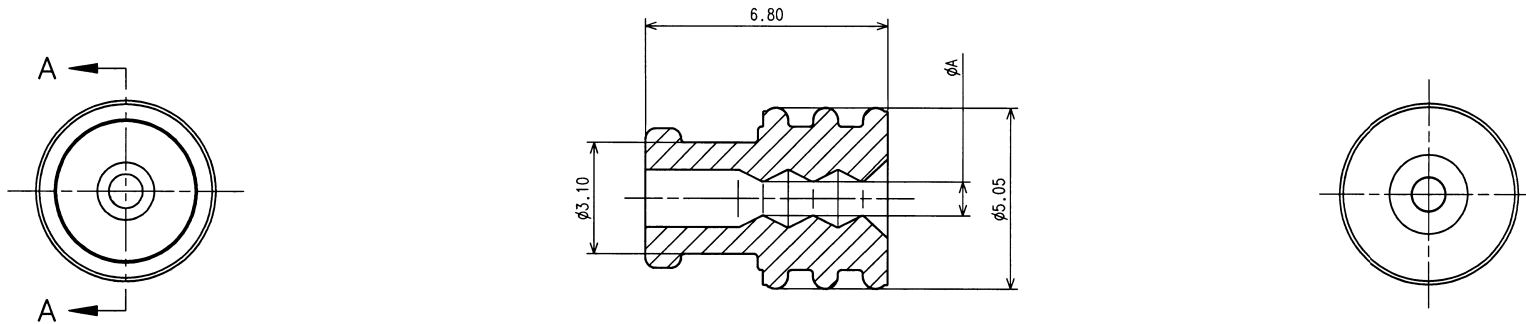

SECTION A-A

NOTES:

- PARTS MUST BE PURCHASED FROM YAZAKI.
- PARTS MUST BE FREE OF FLASH AND IMPERFECTIONS THAT AFFECT FUNCTION.
- APPLICABLE TERMINAL NUMBERS: 7114-4102-02 ETC. (1.5mm YESC)  
7116-4102-02 ETC. (1.5mm YESC)
- APPLICABLE TEMPERATURE: UP TO 125° C.

ISSUE MARK

LET	DATE	REVISION RECORD	NO.	CHKD
-	02.04.05	NEW	C05-A142	C.B.

GENERAL TOLERANCE						
	10 MAX	50 MAX	100 MAX	250 MAX	250 OVR	ANGLE ECCENT
A	±0.15	±0.2	±0.3	±0.5	±0.75	±30' 0.1
B	±0.2	±0.3	±0.55	±0.95	±1.4	±30' 0.1
Ⓞ	±0.3	±0.5	±0.8	±1.4	±2	±30' 0.15
SPECIFIED						WEIGHT

CUSTOMER		MATERIAL SPEC.		TREAT & FIN.	
CUSTOMER PART NO.		CUSTOMER DWG NO.		NAME	
OFFICE		STDLIB NO.		1.5mm RP WIRE SEAL	
VENDOR		VENDOR NO.		PART NO. 7158-3374-90 ETC.	
DWG TYPE		DWG SOURCE		DWG DATE	
R		NEW		02.04.05	
APPROVED		CHECKED		DESIGN	
A. HAYS		A. HAYS		DRAWN	
03.16.05		03.16.05		01.29.03	
03.16.05		03.16.05		03.16.05	
DWG NO. 7158-3374-90:R		TRIAL PART NO.		YAZAKI CORPORATION	

