

1

2

3

4

5

NO.	PARTS NO.	PARTS NAME	MATERIAL
①	7157-7932	DMS CONNECTOR REAR STOPPER	PBT (BROWN)
②		DMS CONNECTOR RUBBER STOPPER	SILICONE RUBBER (BLACK)

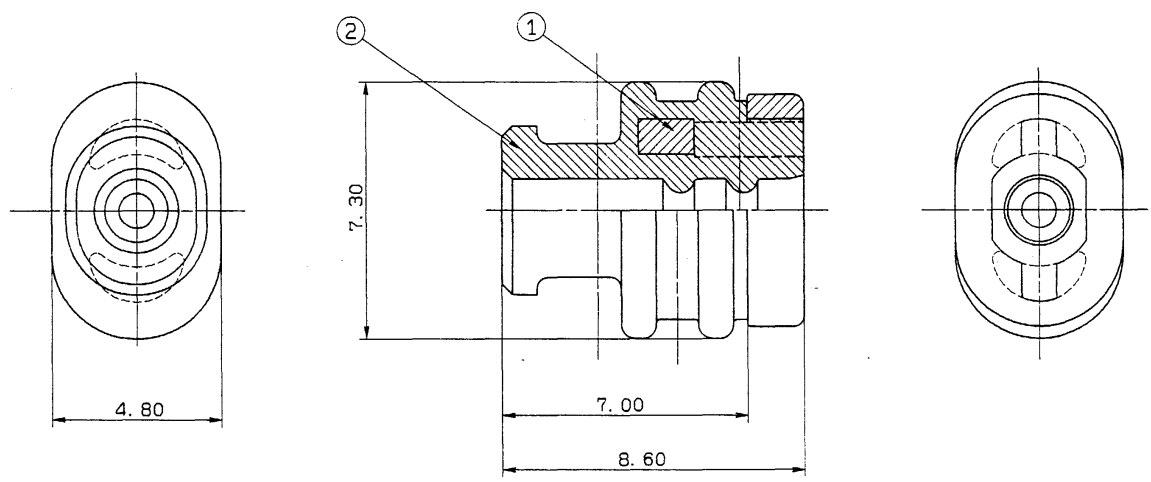

NOTES

- 1) APPLICABLE HOUSING NO. : 7223-7865-30
7223-7866-30
- 2) APPLICABLE TERMINAL NO. : 7116-1520, -1520-08
7116-1521, -1521-08
- 3) APPLICABLE WIRE SIZE : AVSSX 0.5f ~ 0.75f
(COVERED CONDUCTOR DIAMETER : ϕ 1.6 ~ ϕ 1.8)

注記

- 1) 適用ハウジング品番 : 7223-7865-30
7223-7866-30
- 2) 適用ターミナル品番 : 7116-1520, -1520-08
7116-1521, -1521-08
- 3) 適用電線サイズ : AVSSX 0.5f ~ 0.75f
(被覆電線外径 : ϕ 1.6 ~ ϕ 1.8)

ISSUE MARK

LET	DATE	REVISION RECORD	NO.	CHKD
	90.02.26	NEW	C90-6204	S. I

GENERAL TOLERANCE							
	10MAX	50MAX	100MAX	250MAX	2500VR	ANGLE	ECCENT
A	± 0.15	± 0.2	± 0.3	± 0.5	± 0.75	$\pm 30'$	0.1
B	± 0.2	± 0.3	± 0.55	± 0.95	± 1.4	$\pm 30'$	0.1
C	± 0.3	± 0.5	± 0.8	± 1.4	± 2	$\pm 30'$	0.15

CUSTOMER		MATL. SPEC.		TREAT. & FIN.	
CUSTOMER PART NO.	CUSTOMER DWG NO.	SEE TABLE			
		NAME DMS CONNECTOR			
		RUBBER STOPPER			
VENDOR		VENDOR NO.		PART NO. 7157-3891	
DWG TYPE R		DWG SOURCE NEW		DWG DATE 90.02.26	
UNIT mm		SCL 10/1		ANGLE 3	
APPROVED		CHECKED		DESIGN	
DRAWN		DWG NO. 7157-3891:R		TRIAL PART NO.	
YAZAKI CORPORATION					

1

2

3

4

5

1 2 3 4 5

符号	品名	材質	色調
①	リアストップバー	PBT	茶色
②	シールラバー	含シリコンゴム	緑色

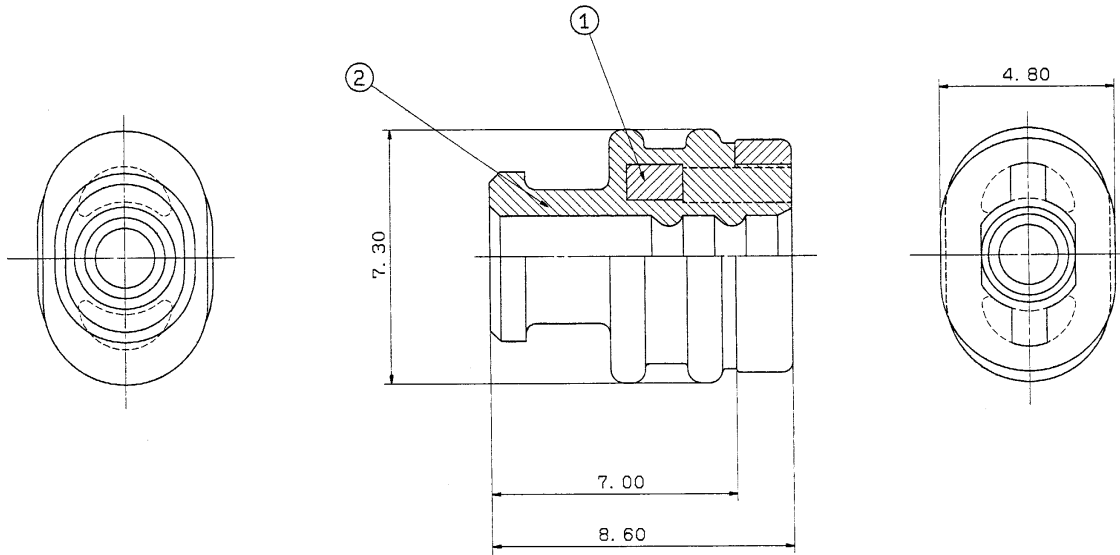

NOTES

1) SUITABLE WIRE SIZE; AVSO. 5~AVO. 85

注記

1) 適用電線サイズ; AVSO. 5~AVO. 85

ISSUE MARK

LET	DATE	REVISION RECORD	NO.	CHKD.
	88.03.11	新 設	BMC-0304	石井

GENERAL TOLERANCE							
	10MAX	50MAX	100MAX	250MAX	250OVR	ANGLE	ECCENT
A	±0.15	±0.2	±0.3	±0.5	±0.75	±30'	0.1
Ⓢ	±0.2	±0.3	±0.55	±0.95	±1.4	±30'	0.1
C	±0.3	±0.5	±0.8	±1.4	±2	±30'	0.15

SPECIFIED

WEIGHT

g

CUSTOMER	CUSTOMER PART NO.	CUSTOMER DWG. NO.	MATL. SPEC.	TREAT. & FIN.
OFFICE	STDLIB NO.		NAME DMSコネクタ	
VENDOR	VENDOR NO. 34栓 (0.5.0.85SQ用)			
DWG TYPE DWG SOURCE DWG DATE UNIT SCL ANGLE			PART NO. 7157-7933	
APPROVED CHECKED CHECKED DESIGN DRAWN			DWG NO. 7157-7933-R TRIAL PART NO.	
88.03.18 88.03.18 87.03.02 88.03.11			YAZAKI CORPORATION	

1

2

3

4

5

NO.	NAME	MATERIAL	COLOR
①	REAR STOPPER	PBT	BLACK
②	SEAL RUBBER	SELF-LUBRICATION SILICONE RUBBER	RED IRON OXIDE

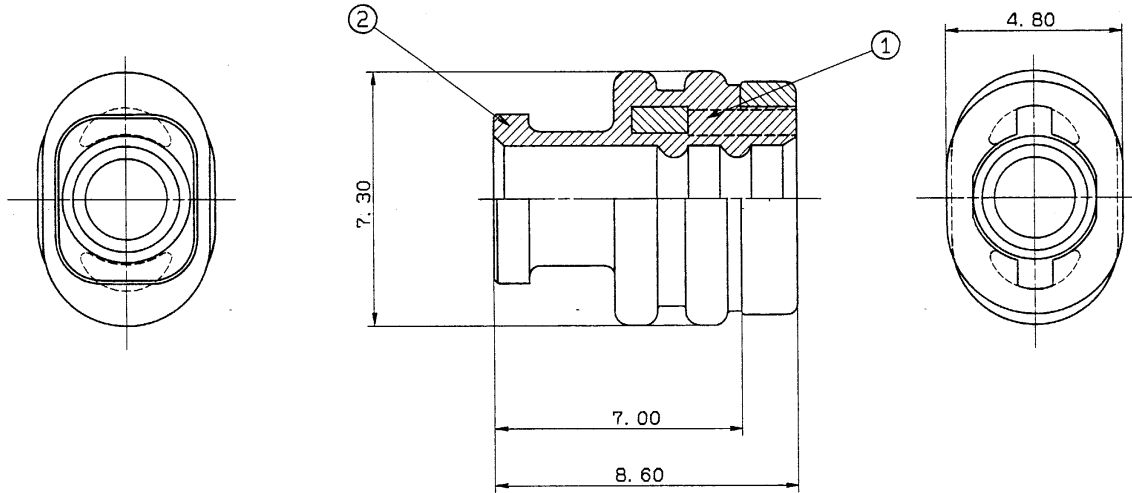

△ NOTE

1) APPLICABLE WIRE SIZE: AVS1.25~AVSS2.0

注記

△ 1) 適用ワイヤサイズ: AVS1.25~AVSS2.0

ISSUE MARK

LET	DATE	REVISION RECORD	NO.	CHKD
△	90.04.09	CHANGED NOTES	C90-L240	M. K
	88.03.11	新 製	SMC-0304	石井

GENERAL TOLERANCE							
	10MAX	50MAX	100MAX	250MAX	2500VR	ANGLE	ECCENT
A	±0.15	±0.2	±0.3	±0.5	±0.75	±30'	0.1
Ⓞ	±0.2	±0.3	±0.55	±0.95	±1.4	±30'	0.15
C	±0.3	±0.5	±0.8	±1.4	±2	±30'	0.15
SPECIFIED						WEIGHT	
						g	

CUSTOMER		MATT. SPEC.		TREAT. & FIN.	
CUSTOMER PART NO.		CUSTOMER DWG NO.			
OFFICE		STDLIB NO.		NAME DMS CONNECTOR	
VENDOR				SEAL RUBBER (FOR 1.25, 2SQ)	
VENDOR NO.				PART NO. 7157-7935	
DWG TYPE	DWG SOURCE	DWG DATE	UNIT	SCL	ANGLE
R	NEW	87.03.16	mm	10	3
APPROVED	CHECKED	CHECKED	DESIGN	DRAWN	
高野	八木	石井	石井	M. KAI	
90.4.19	90.4.18	90.4.13	87.03.16	90.04.09	
DWG NO. 7157-7935:R				TRIAL PART NO.	
YAZAKI CORPORATION					