

PART NO. AND CH. CODE	$\Delta W_1 \pm 0.4$	$\Delta W_2 \pm 0.4$	1			WIRE SIZE	MATERIAL
			H ₁	H ₂	X		
7116-4035	2.90	5.40	$\Delta(2.62)$	$\Delta(4.52)$	0.40	AVS 0.3~AVS 0.5 EQUIVALENT	C2600 (t=0.40) TIN PLATING
7116-4036	3.60	5.70	$\Delta(3.34)$	$\Delta(4.38)$	0.60	AVS 0.5~AVS 1.25 EQUIVALENT	C2600 (t=0.40) TIN PLATING
7116-4037	4.90	6.90	$\Delta(4.63)$	$\Delta(5.42)$	0.80	AVS 2~AVS 3 Δ AVX 3 EQUIVALENT	Δ COPPER ALLOY (t=0.40) Δ TIN PLATING

注記

1. 対応相手品番: 7114-4035 ETC.

Δ 2. 適用寸法品番: 7158-3014-90 ETC.

NOTES

1. MATING PART NO.: 7114-4035 ETC.

Δ 2. APPLICABLE RUBBER STOPPER NO.:
7158-3014-90 ETC.

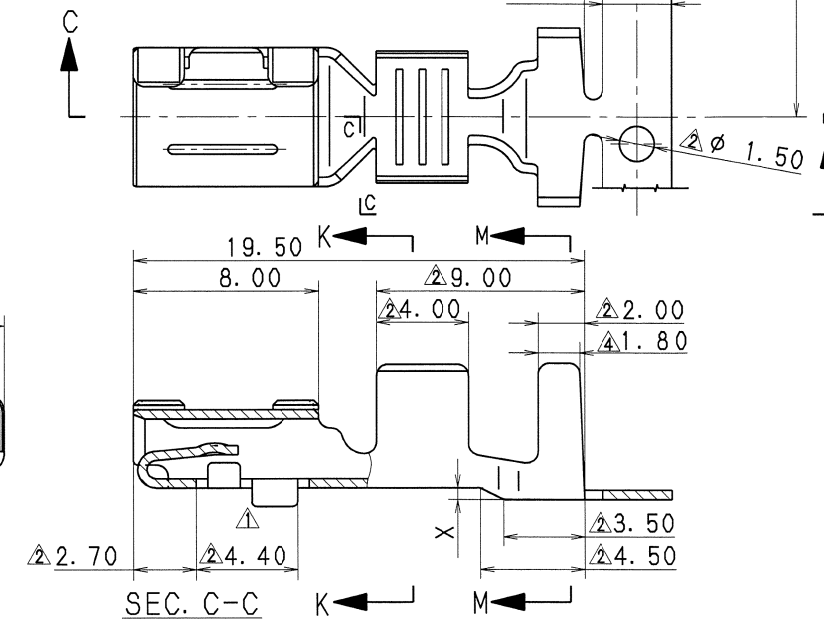
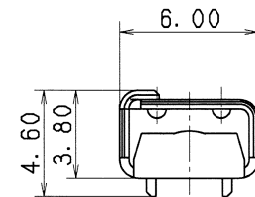
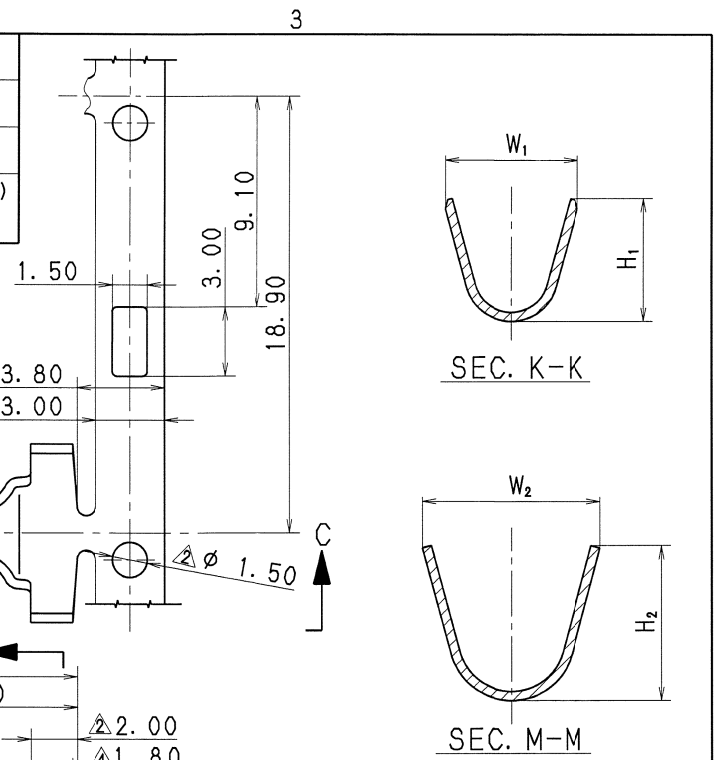

Δ	2017/03/30	CORRECTION OF CLERICAL ERROR	C17-Z126	A. Q
Δ	2007/04/19	CHANGED APPLICABLE WIRE SIZE, ETC.	C07-Z331	T. H
Δ	1998/07/18	CHANGED DIMENSION, MATERIAL & ADDED NOTE	C97-N462	H. K
Δ	1990/03/06	CHANGED FORM	C90-L254	K. O
Δ	1989/10/11	NEW	C89-M089	H. Y
LET	DATE	REVISION RECORD	NO.	CHKD

GENERAL TOLERANCE								
	10MAX	50MAX	100MAX	250MAX	2500VR	ANGLE	ECCENT	
A	± 0.15	± 0.2	± 0.3	± 0.5	± 0.75	$\pm 30'$	0.1	
B	± 0.2	± 0.3	± 0.55	± 0.95	± 1.4	$\pm 30'$	0.1	
C	± 0.3	± 0.5	± 0.8	± 1.4	± 2	$\pm 30'$	0.15	
SPECIFIED							MASS	g

CUSTOMER		MATL. SPEC.	SEE TABLE	TREAT. & FIN.
CUSTOMER PART NO.		CUSTOMER DWG NO.		
OFFICE		TRIAL PART NO.		NAME Δ 4.8 SEALED TERMINAL FEMALE
VENDOR		VENDOR NO.		
DWG TYPE	DWG SOURCE	DWG DATE	UNIT	SCL
R	NEW	1989/10/24	mm	2.5:1
APPROVED	CHECKED	CHECKED	DESIGN	DRAWN
S. SUZUKI	S. ONODA		SUEYOSHI	A. QUIROL
2017/03/30	2017/03/30		1987/03/04	2017/03/30
PART NO. CH. CODE		7116-4035 ETC.		
DWG NO.		7116-4035:R		SET DWG NO.
YAZAKI CORPORATION				