

YAZAKI PART NO.	PLATING
7116-3050	
7116-3050-02	TIN PLATING

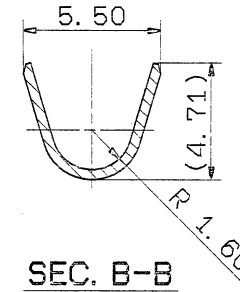
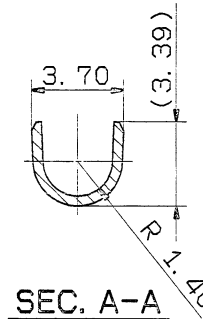
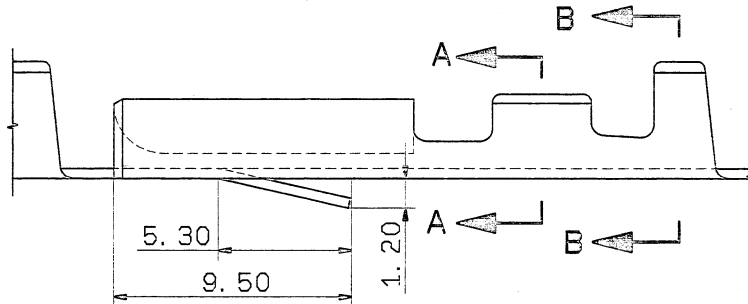
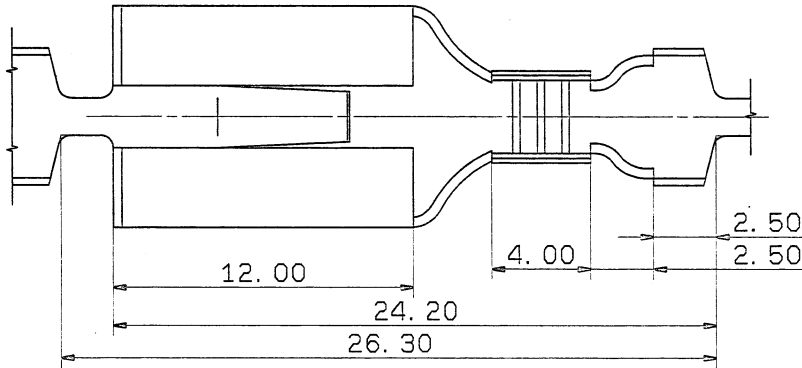
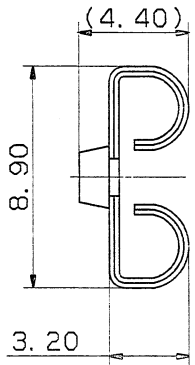

注記

- 嵌合相手品番 : 7114-3030
- 適用電線サイズ: AVS 0.5~2.0

NOTE

- MATING PART NO. : 7114-3030
- APPLICABLE WIRE SIZE: AVS 0.5~2.0

ISSUE MARK

				CUSTOMER				MATL. C2600				TREAT.					
				CUSTOMER PART NO.				SPEC. t=0.4				& FIN.					
95.06.07				NEW				C95-L915				K.O					
LET				DATE				REVISION RECORD				NO. CHKD					
				OFFICE				TRIAL PART NO.				NAME 305(7.8mm) TERMINAL FEMALE					
				VENDOR													
				GENERAL TOLERANCE				VENDOR NO.									
	10MAX	50MAX	100MAX	250MAX	250OVR	ANGLE	ECCENT	DWG TYPE	DWG SOURCE	DWG DATE	UNIT	SCL	ANGLE	PART NO.	7116-3050 ETC.		
A	±0.15	±0.2	±0.3	±0.5	±0.75	±30'	0.1	R	NEW	95.06.07	mm	5/1	3	CH. CODE	7116-3050:R		
B	±0.2	±0.3	±0.55	±0.95	±1.4	±30'	0.1	APPROVED	CHECKED	CHECKED	DESIGN	DRAWN	DWG NO.	7116-3050:R			
©	±0.3	±0.5	±0.8	±1.4	±2	±30'	0.15	TAKENOUCHI		SAMUKAWA				YAZAKI CORPORATION			
SPECIFIED				MASS				g				81.06.05 95.06.07					

YAZAKI PART NO.	MATERIAL	PLATING	INSERTION FORCE	SEPARATION FORCE
7116-3060	C2600R		Δ MAX. 58. 8N(6kgf)(1-5 TIMES)	Δ 14. 7~58. 8N(1. 5~6. 0kgf)(1-5 TIMES)
7116-3060-02	C2600R TIN PLATE	TIN PLATE	Δ MAX. 58. 8N(6kgf)(1-5 TIMES)	Δ 14. 7~58. 8N(1. 5~6. 0kgf)(1-5 TIMES)

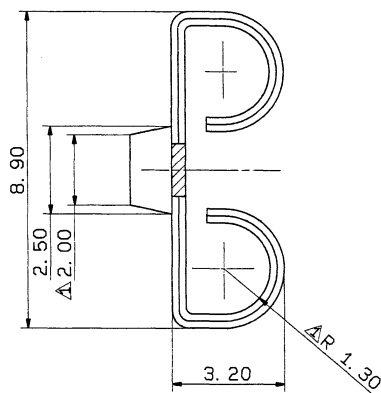

VIEW X (10/1)

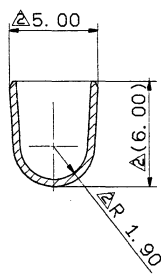
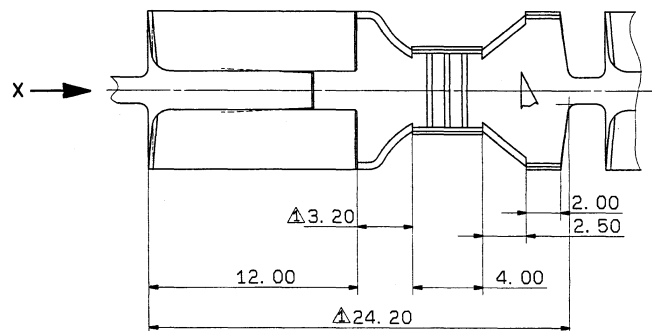

SEC. Y-Y

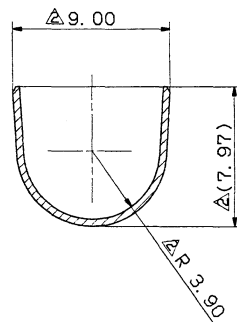

SEC. Z-Z

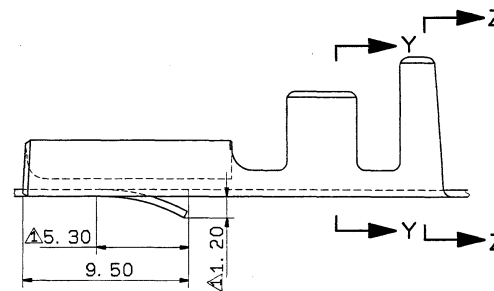

NOTES

- UNLESS OTHERWISE SPECIFIED
ALL RADII TO BE 0.5 RADIUS.
- APPLICABLE WIRE SIZE AV3 TO AV5.
- MATING PART NO. 7114-3030 ETC. .

注記

- 指示半径は、全てR0.5とする。
- 適用ワイヤは、AV3~5とする。
- 適合相手は、7114-3030 ETC. とする。

GENERAL TOLERANCE						
	10MAX	50MAX	100MAX	250MAX	2500VR	ANGLE
A	± 0.15	± 0.2	± 0.3	± 0.5	± 0.75	$\pm 30'$
B	± 0.2	± 0.3	± 0.55	± 0.95	± 1.4	$\pm 30'$
C	± 0.3	± 0.5	± 0.8	± 1.4	± 2	$\pm 30'$
SPECIFIED						0.15
MASS						1.4 g

CUSTOMER		MATERIAL SPEC.		TREAT.	
CUSTOMER PART NO.	CUSTOMER DWG NO.	SEE TABLE	SEE TABLE	SEE TABLE	SEE TABLE
OFFICE	TRIAL PART NO.	NAME 305(7.8MM) TERMINAL FEMALE			
VENDOR		PART NO. 7116-3060 ETC.			
VENDOR NO.		CH. CODE 7116-3060:R			
DWG TYPE	DWG SOURCE	DWG DATE	UNIT	SCL	ANGLE
R	NEW	76.10.28	mm	5/1	3
APPROVED	CHECKED	CHECKED	DESIGN	DRAWN	DWG NO.
			KUMURA	KOSAKA	7116-3060:R
YAZAKI CORPORATION					

LET	DATE	REVISION RECORD	NO.	CHKD
Δ	94.10.20	CHANGED FORM	C94-M507	M. K
Δ	84.08.02	CHANGED FORM & RENEW	C84-5770	T. M
	76.10.28	NEW	C6-722	HORI

1

2

3

4

5