

NO.	MATERIAL	SHEET-METAL GAGE
①	CAC92	t=0.3
②	KFC (TIN PLATING)	t=0.4

YAZAKI NO.	C	Φ	A	B	APPLICABLE WIRE SIZE
7116-2879	4.1	6.2	8.1	4.7	AV(S)2 ~ AV(S)3
7116-2878	3.3	5.3	6.2	3.1	AV(S)0.5 ~ AV(S)1.25

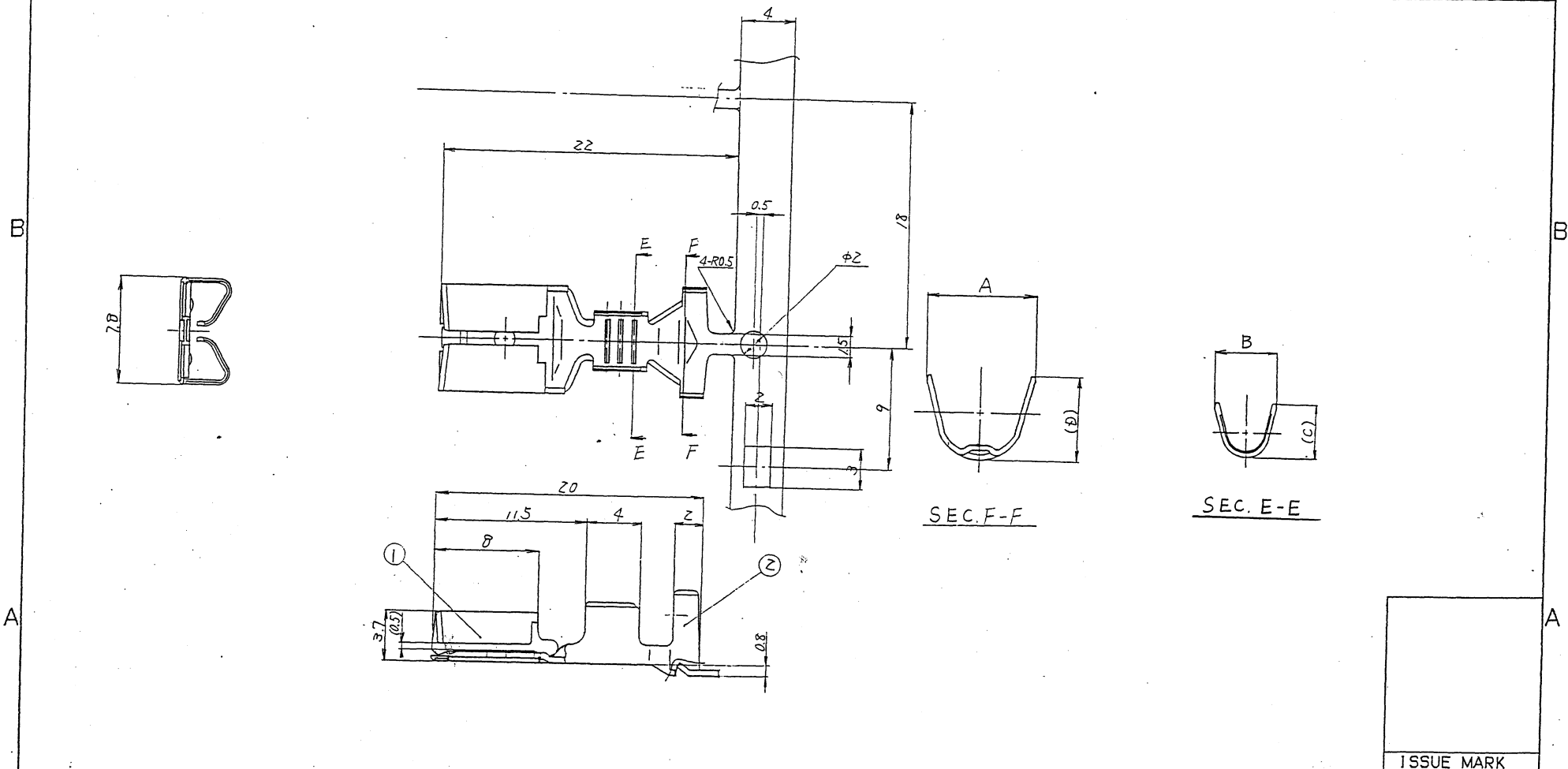

ISSUE MARK

CUSTOMER										MATL. SPEC. SEE TABLE			TREAT. & FIN.									
CUSTOMER PART NO.					CUSTOMER DWG NO.					NAME X TYPE (XF-H) HEAVY DUTY												
89.09.07 NEW C89-L858 S.I OFFICE										STDLIB NO.			TERMINAL (F)									
LET DATE REVISION RECORD NO. CHKD VENDOR										VENDOR NO.			PART NO. 7116-2879 ETC.									
GENERAL TOLERANCE										DWG TYPE R			DWG SOURCE NEW		DWG DATE 89.09.07		UNIT mm		SCL FREE		ANGLE 3	
10MAX		50MAX		100MAX		250MAX		2500VR		ANGLE		ECCENT		PART NO.		DWG NO.		TRIAL PART NO.				
A ±0.15		±0.2		±0.3		±0.5		±0.75		±30°		0.1		APPROVED		CHECKED		CHECKED				
B ±0.2		±0.3		±0.55		±0.95		±1.4		±30°		0.1		DESIGN		DRAWN		S.INABA				
C ±0.3		±0.5		±0.8		±1.4		±2		±30°		0.15		T. Endo		Takanashi		Zakita				
SPECIFIED WEIGHT										9		89.09.15		89.09.12		89.09.08		89.09.07		YAZAKI CORPORATION		