

注記

- 1) かん合雄端子品番: 7114-1230 ETC.
- 2) () 内品番は、エアバッグ (A/B) 回路及び特別管理回路に使用する時に適用すること。

NOTES

- 1) MATING MALE TERMINAL NO. : 7114-1230 ETC.
- 2) PART NUMBERS IN PARENTHESIS SHALL BE USED FOR AIR BAG (A/B) CIRCUITS AND OTHER CIRCUITS DESIGNATED FOR SPECIAL MONITORING.

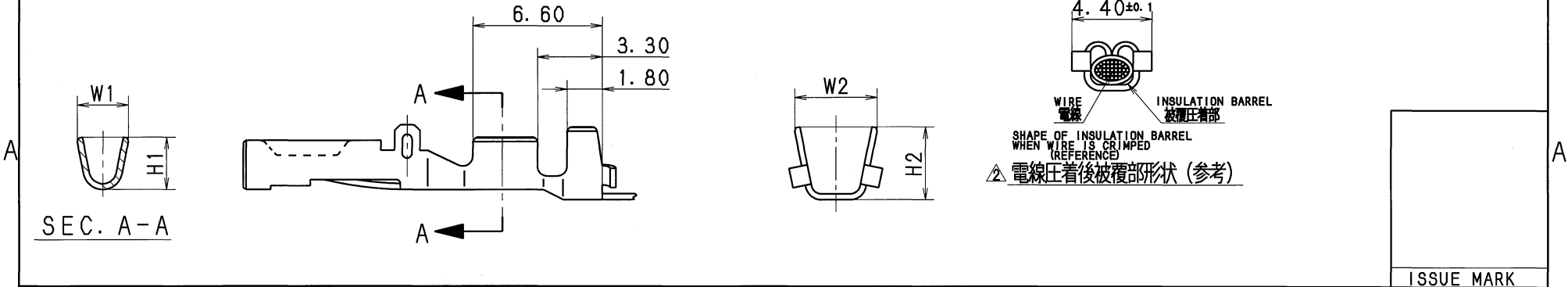

電線圧着後被覆部形状 (参考)

11. 10. 26	ADDED VIEW ETC.	C11-Z814	K. U	CUSTOMER		MATL. SPEC. Δ BRASS (t=0.3)	TREAT. & FIN.
93. 10. 14	ADDED PART NO.	C93-7035	M. K	CUSTOMER PART NO.		CUSTOMER DWG NO.	
89. 02. 07	NEW	C89-L257	T. M	OFFICE		NAME Δ S TYPE TERMINAL FEMALE	
LET	DATE	REVISION RECORD NO.	CHKD	VENDOR		TRIAL PART NO.	
GENERAL TOLERANCE				VENDOR NO.			
A	±0.15	±0.2	±0.3	±0.5	±0.75	±30'	0.1
B	±0.2	±0.3	±0.55	±0.95	±1.4	±30'	0.1
©	±0.3	±0.5	±0.8	±1.4	±2	±30'	0.15
SPECIFIED				MASS g			
				11. 10. 26		82. 09. 14 11. 10. 26	
				M. KASHIYAMA		ISHIZUKA K. URANO	
				APPROVED		DESIGN DRAWN	
				CHECKED		CHECKED	
				DWG TYPE R		DWG SOURCE NEW	
				DWG DATE 89. 02. 18		UNIT mm	
				SCL 5/1		ANGLE 3	
				PART NO. 7116-1230 ETC.		CH. CODE	
				DWG NO. 7116-1230:R		SET DWG NO.	
YAZAKI CORPORATION							