

注記

1. かん相手品番 : 7116-4231-08, 7116-4231-02
2. 適用電線サイズ : CAVUS 0.3~CAVS 0.5
3. ( ) 内品番は、エアバッグ (A/B) 回路及び特別管理回路に使用する時に適用すること。

NOTES

1. MATING PART NO. : 7116-4231-08, 7116-4231-02
2. APPLICABLE WIRE SIZE : CAVUS 0.3~CAVS 0.5
3. PART NUMBERS IN PARENTHESIS SHALL BE USED FOR AIR BAG (A/B) CIRCUITS AND OTHER CIRCUITS DESIGNATED FOR SPECIAL MONITORING.

PART NO. AND CH. CODE	TREATMENT
7114-4231-08, (A)	3. GOLD PLATING
(7B14-4231-08, (A) )	1. TIN PLATING
7114-4231-02	TIN PLATING
(7B14-4231-02)	

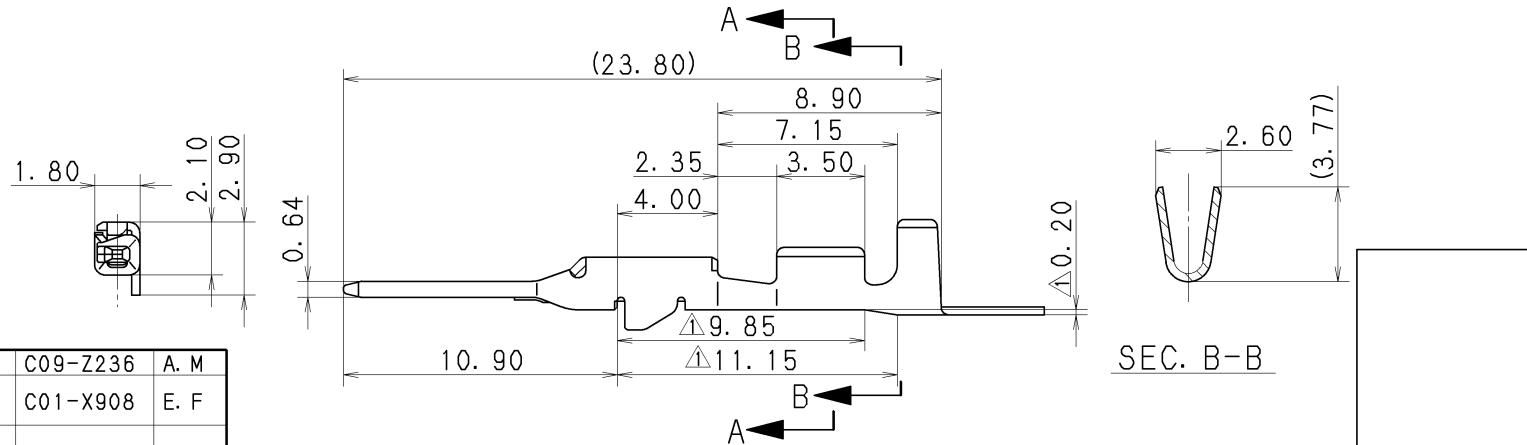
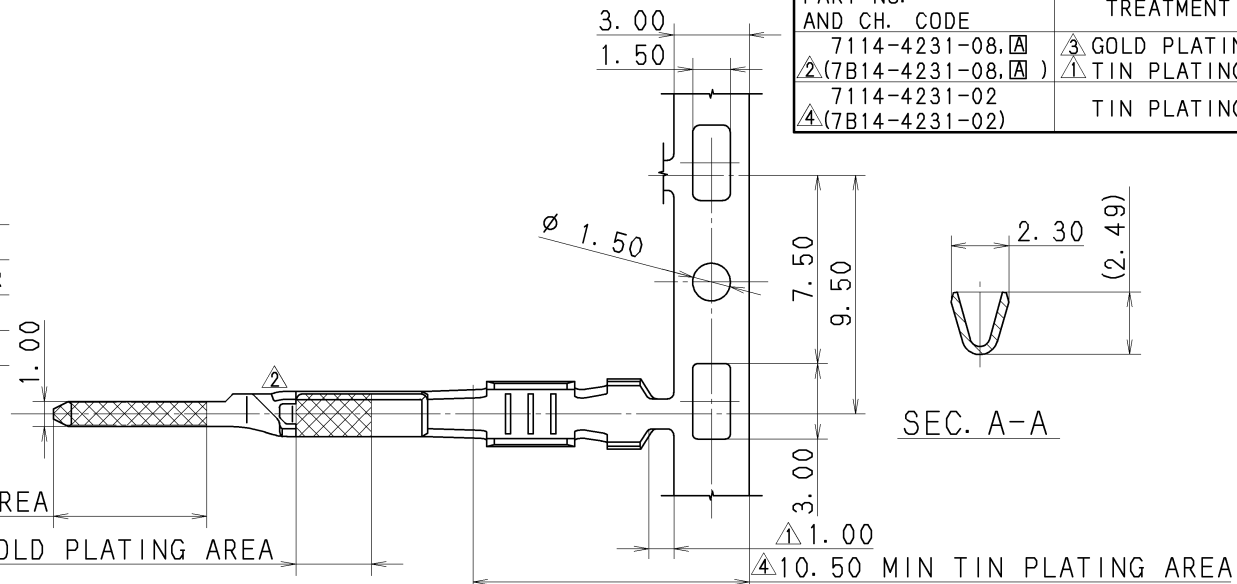

4	09/03/12	ADDED NOTES, ETC.	C09-Z236	A. M
3	01. 10. 24	CHANGED TREATMENT & PART NAME, (A)	C01-X908	E. F
2	98. 11. 07	ADDED NOTE, A/B PART NO. & CHANGED FORM	C98-M816	T. H
1	98. 08. 04	CHANGED DIMENSION & PLATING	C97-N441	H. K
LET	DATE	REVISION RECORD	NO.	CHKD

GENERAL TOLERANCE						
	10MAX	50MAX	100MAX	250MAX	2500VR	ECCENT
A	±0.15	±0.2	±0.3	±0.5	±0.75	0.1
B	±0.2	±0.3	±0.55	±0.95	±1.4	0.1
(C)	±0.3	±0.5	±0.8	±1.4	±2	0.15
SPECIFIED						MASS
						g

CUSTOMER		MATL. SPEC.	4 BRASS (t=0.32)	TREAT. & FIN.	SEE TABLE
CUSTOMER PART NO.		CUSTOMER DWG NO.		NAME	
OFFICE		TRIAL PART NO.		4 1.0 III TERMINAL MALE	
VENDOR		VENDOR NO.		PART NO. 7114-4231-08 ETC. (7B14-4231-08 ETC.)	
DWG TYPE		DWG SOURCE	DWG DATE	UNIT	SCL
R	NEW	97.03.31	mm	5/1	3
APPROVED	CHECKED	CHECKED	DESIGN	DRAWN	
M. YAMANASHI	T. MIWA	R. UNO	S. YAMADA	S. CALDEA	
09/03/12	09/03/12	09/03/12	96.10.04	09/03/12	
DWG NO. 7114-4231-08:R				SET DWG NO.	
YAZAKI CORPORATION					