

YAZAKI PART NO. AND CH. CODE	H1	W1	H2	W2	△T1	△T2	APPLICABLE WIRE SIZE	TREAT & FIN.
7114-1470 △(7B14-1470)	2.5	2.6	3.9	4.2	10.0	5.0	AVS 0.3-0.85	TIN PLATING GOLD PLATING
7114-1470-08 △(7B14-1470-08)	3.2	3.2	4.2	4.3	11.2	5.6	AVS 1.25 AVSS 2.0	TIN PLATING GOLD PLATING

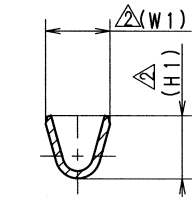

SEC. A-A

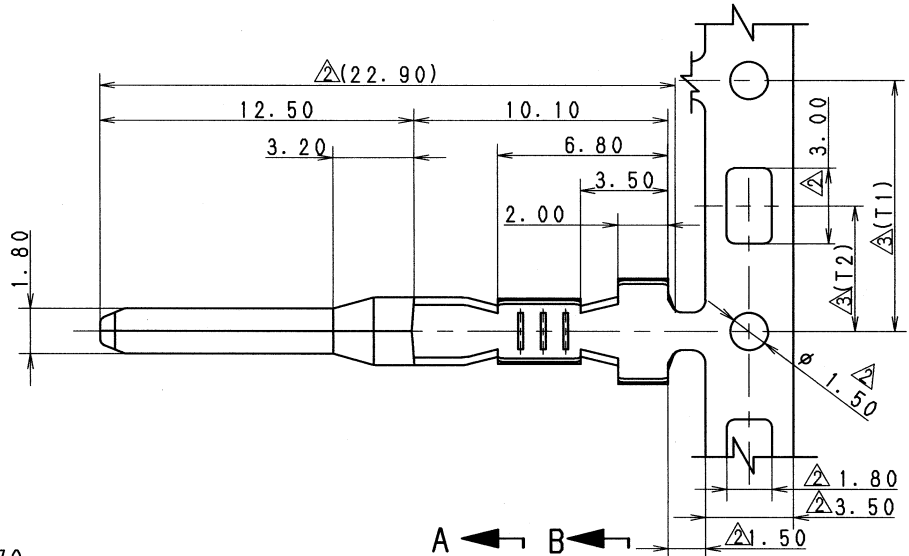
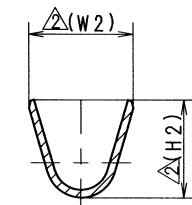

SEC. B-B

△ 注記

- 嵌合雌ターミナル品番：7116-1470 ETC.
- 適用雄ハウジング品番：7122-1965-30 ETC.
- () 内品番は、エアバッグ (A/B) 回路及び特別管理回路に使用する時に適用すること。
- 本寸法は7114-1470-08 (7B14-1470-08) 及び7114-1475-08に適用。

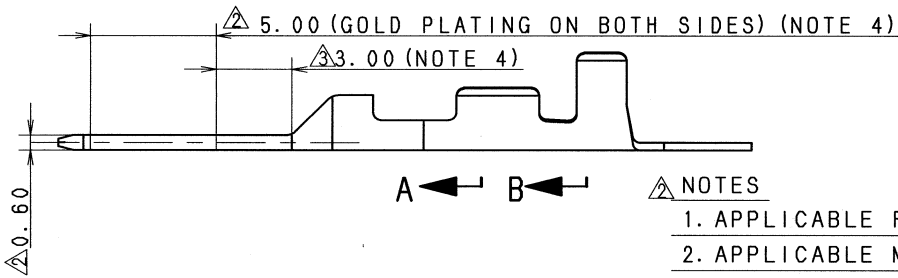
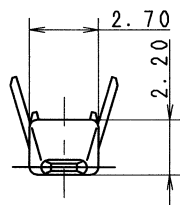

△ NOTES

- APPLICABLE FEMALE TERMINAL NO. : 7116-1470 ETC.
- APPLICABLE MALE HOUSING NO. : 7122-1965-30 ETC.
- PART NUMBERS IN PARENTHESIS SHALL BE USED FOR AIR BAG (A/B) CIRCUITS AND OTHER CIRCUITS DESIGNATED FOR SPECIAL MONITORING.
- THIS DIMENSION IS APPLIED TO 7114-1470-08 (7B14-1470-08) AND 7114-1475-08.

△ 07/05/10	ADDED DIMENSION, ETC.	C07-Z371	T. K					MATERIAL SPEC. BRASS (t=0.3)		TREAT. & FIN. SEE TABLE		ISSUE MARK						
△ 06/07/11	ADDED A/B PART NO., ETC.	C06-Z656	T. K	CUSTOMER				CUSTOMER DWG NO.		NAME 070 TYPE TERMINAL MALE								
△ 90/02/05	CHANGED TOLERANCE AND CORRECTION OF CLERICAL ERROR	C90-6120	M. K	CUSTOMER PART NO.				OFFICE		TRIAL PART NO.								
87/03/19	NEW	7MC-4042	H. S	VENDOR				VENDOR NO.										
LET	DATE	REVISION RECORD	NO.	CHKD	DWG TYPE				DWG SOURCE		DWG DATE		UNIT	SCL	ANGLE	PART NO.	CH. CODE △ 7114-1470 ETC. (7B14-1470 ETC.)	
△ GENERAL TOLERANCE				APPROVED				CHECKED		CHECKED		DESIGN		DRAWN		DWG NO. 7114-1470:R		SET DWG NO.
	10MAX	50MAX	100MAX	250MAX	2500VR	ANGLE	ECCENT	S. YAGI		C. AGCAOILI		YAZAKI CORPORATION						
A	±0.15	±0.2	±0.3	±0.5	±0.75	±30'	0.1	YOSHIDA (典)		INOUE (隆)		KOMORI		84/12/21		07/05/10		
B	±0.2	±0.3	±0.55	±0.95	±1.4	±30'	0.1	07.05.10		07.05.10		07.5.10						
©	±0.3	±0.5	±0.8	±1.4	±2	±30'	0.15	g										