

NOTES

- △ 1. MATING PART NO. : 7116-1466-02 ETC. (7B16-1466-02 ETC.)
- △ 2. APPLICABLE WIRE SEAL NO. : 7158-3120-90 (7B58-3120-90)
7158-3121-80 (7B58-3121-80)
- △ 3. PART NUMBERS IN PARENTHESIS SHALL BE USED FOR AIR BAG (A/B) CIRCUITS AND OTHER CIRCUITS DESIGNATED FOR SPECIAL MONITORING.
- △ 4. Au PLATE IN * DIMENSION AREA (7B14-1466-08, 7B14-1469-08)

PART NO. AND CH. CODE	P	W	APPLICABLE WIRE SIZE	MATERIAL
7114-1466-02	2.15	3.95	CAVS 0.3~0.5 CAVUS 0.3~0.5	BRASS (t=0.25)
△(7B14-1466-02)				TIN PLATING
7114-1466-08				BRASS (t=0.25)
△(7B14-1466-08)	2.65	4.10	CAVS 0.85 CAVUS 0.85	GOLD PLATING
7114-1469-02				BRASS (t=0.25)
△(7B14-1469-02)				TIN PLATING
7114-1469-08				BRASS (t=0.25)
△(7B14-1469-08)				GOLD PLATING

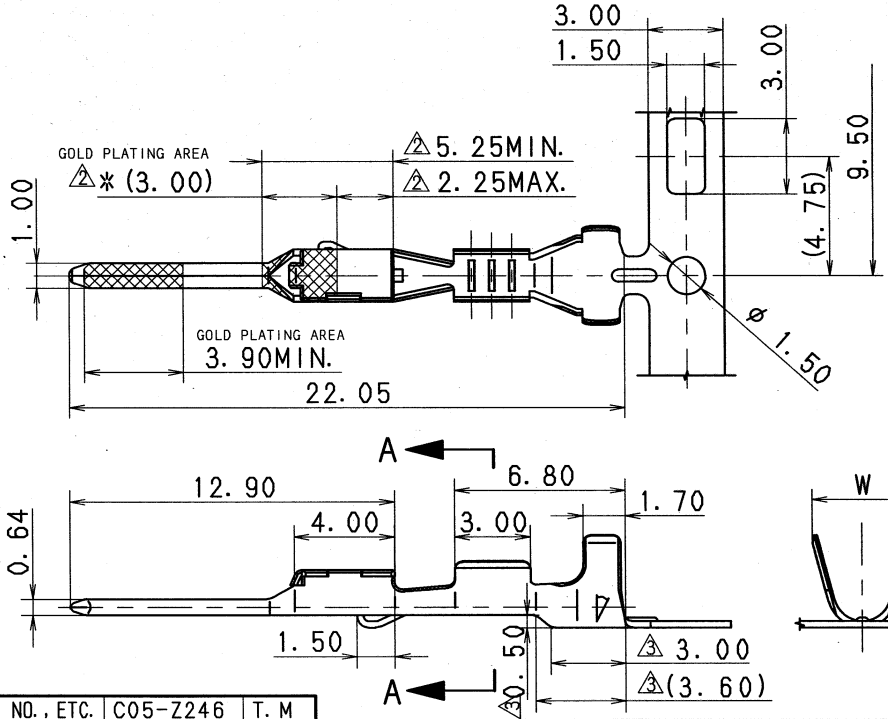

注記

- △ 1. 嵌合相手品番 : 7116-1466-02 ETC. (7B16-1466-02 ETC.)
- △ 2. 適用ゴム栓品番 : 7158-3120-90 (7B58-3120-90)
7158-3121-80 (7B58-3121-80)
- △ 3. () 内品番は、エアバック (A/B) 回路及び特別管理回路に使用する時に適用すること。
- △ 4. *寸法の金メッキ範囲は、7B14-1466-08, 7B14-1469-08のみ適用とする。

△ 05/03/02	ADDED A/B PART NO., ETC.	C05-Z246	T. M	CUSTOMER		MATL. SPEC.	SEE TABLE	TREAT. & FIN.	SEE TABLE	ISSUE MARK					
△ 00/08/21	CORRECTION OF A CLERICAL ERROR	C00-6778	M. F	CUSTOMER PART NO.											
△ 00/01/19	CHANGED FORM ETC.	C00-L091	T. H	CUSTOMER DWG NO.											
98/03/19	NEW	C98-L459	M. I	OFFICE		NAME		RK-TYPE TERMINAL MALE							
LET	DATE	REVISION RECORD NO.	CHKD	VENDOR		TRIAL PART NO.									
GENERAL TOLERANCE				VENDOR NO.											
	10MAX	50MAX	100MAX	250MAX	250OVR	ANGLE	ECCENT	DWG TYPE	DWG SOURCE	DWG DATE	UNIT	SCL	ANGLE	PART NO. △7114-1466-02 ETC. (7B14-1466-08 ETC.)	
A	±0.15	±0.2	±0.3	±0.5	±0.75	±30'	0.1	R	NEW	98/03/19	mm	5:1	3	DWG NO. 7114-1466-02:R	
B	±0.2	±0.3	±0.55	±0.95	±1.4	±30'	0.1	APPROVED	CHECKED	CHECKED	DESIGN	DRAWN		SET DWG NO.	
◎	±0.3	±0.5	±0.8	±1.4	±2	±30'	0.15								
SPECIFIED				MASS		g								YAZAKI CORPORATION	