

注記

1. 適用電線サイズ: CAVUS 0.3~AVS 0.5
2. () 内品番は、エアバッグ (A/B) 回路及び特別管理回路に使用する時に適用すること。
- △ 3. 嵌合相手品番: 7116-1257-02 ETC.

NOTES

1. APPLICABLE WIRE SIZE: CAVUS 0.3~AVS 0.5
2. PART NUMBERS IN PRENTHESIS SHALL BE USED FOR AIR BAG (A/B) CIRCUITS AND OTHER CIRCUITS DESIGNATED FOR SPECIAL MONITORING.
- △ 3. MATING PART NO. : 7116-1257-02 ETC.

B

A

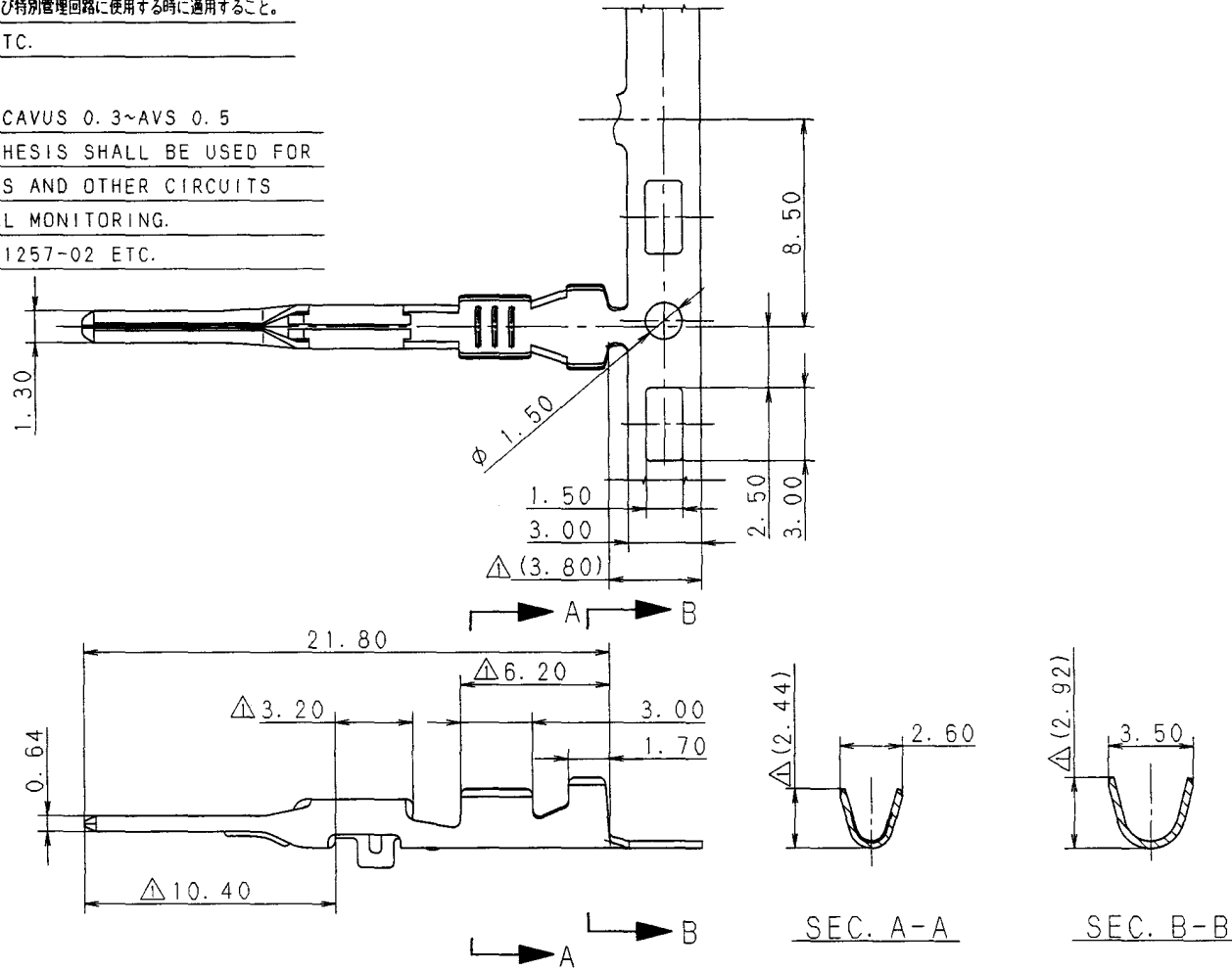

ISSUE MARK

△ 98.11.26	CHANGED FORM & NOTE. [A]	C98-N013	T. M	CUSTOMER	MATL. △ C2600 (t=0.30)	TREAT. & FIN.
△ 98.08.04	CHANGED NOTE & DIMENSION	C97-N444	H. K	CUSTOMER PART NO.	SPEC. TIN PLATING	
97.01.07	NEW	C96-N191	H. K	CUSTOMER DWG NO.	NAME 050 TERMINAL MALE	
LET	DATE	REVISION RECORD	NO.	CHKD	VENDOR	
GENERAL TOLERANCE				VENDOR NO.		
	10MAX	50MAX	100MAX	250MAX	2500VR	ANGLE
A	±0.15	±0.2	±0.3	±0.5	±0.75	±30'
B	±0.2	±0.3	±0.55	±0.95	±1.4	±30'
③	±0.3	±0.5	±0.8	±1.4	±2	±30'
SPECIFIED				MASS	g	
				98.12.07	98.12.07	98.12.07
				加藤	山梨	福
				WATANABE	KANAZAWA	杉山
				88.09.08	98.11.26	
PART NO. 7114-1257-02 (7B14-1257-02) [A]					DWG NO. 7114-1257-02:R	
YAZAKI CORPORATION					SET DWG NO.	