

D

THIS DRAWING AND DESIGN HEREON CONSTITUTES A PROPRIETARY DESIGN OF PACKARD ELECTRIC DIVISION AND IS NOT TO BE DUPLICATED OR REPRODUCED WITHOUT AUTHORITY OF PACKARD ELECTRIC DIVISION.

DO NOT SCALE

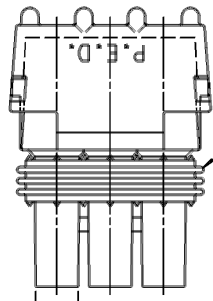

SEALING RIBS MUST BE FREE OF DEFECTS.

6.15 DIA. - 3 PLCS.

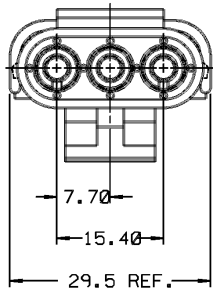

INDEX CODE  
-101-  
(ALSO SEE HANDBOOK)

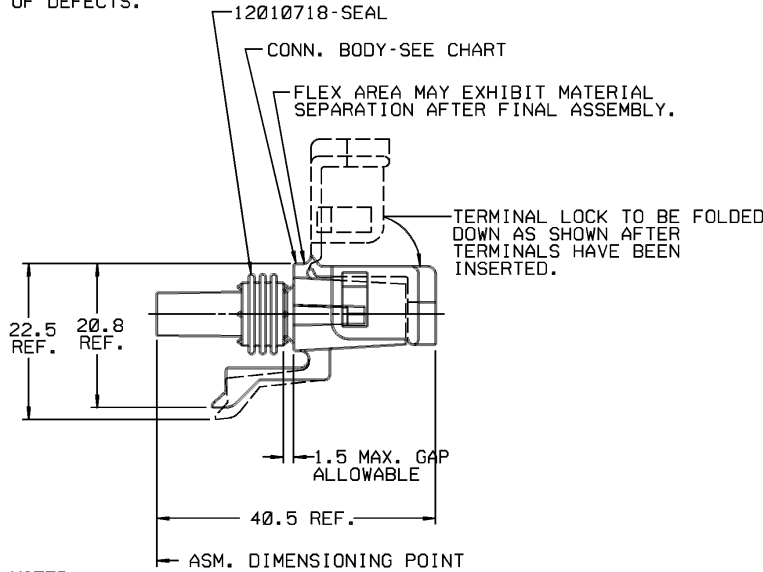
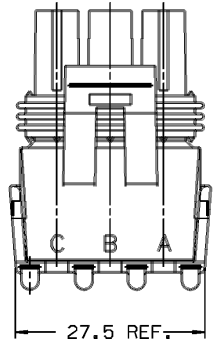

NOTES

- UNLESS OTHERWISE SPECIFIED AND/OR INDICATED:  
DIMENSIONS ARE TO FACE OF VIEW SHOWN AND AUTOMATICALLY ROUNDED BY COMPUTER FOR INSPECTION (SEE MATH MODEL FOR PRECISE DIMENSIONS). FOR ALL OTHER DIMENSIONS NOT SHOWN BUT REQUIRED FOR TOOL BUILD, SEE MATH MODEL FOR PRECISE TOOL PATH DATA.
- USE FEMALE TERMINAL 12089188 OR EQUIVALENT FOR "IN-LINE" APPLICATIONS. USE MALE TERMINAL 12089040 OR EQUIVALENT FOR "PANEL MOUNT" APPLICATIONS.
- USE CABLE SEAL 12015323 OR EQUIVALENT.
- MATING CONNECTOR - SEE CHART.
- WHEN PARTS ARE SHIPPED THEY MUST BE PACKED IN PLASTIC BAGS OR SHIPPING CONTAINERS MUST BE LINED WITH PLASTIC LINERS. BAGS OR LINERS MUST BE SEALED TO AVOID FOREIGN MATTER.
- SEALING CODE 3 - DESIGN WILL PASS SALT FOG AND IMMERSION TEST AFTER CONDITIONING AS SPECIFIED IN ESA-644 (WEATHER-PACK), ESA-710 (METRI-PACK), ESA-650 (UNDERHOOD MICRO-PACK), C-4006 (WORLD CONNECTOR), ETC WHEN MATED TO MATING PART OR EQUIVALENT
- THIS PRODUCT IS NOT CATEGORIZED AS AN APPEARANCE ITEM, MINOR IMPERFECTIONS INCLUDING, BUT NOT LIMITED TO, FLOW MARKS, COLOR BLEMISHES, GATE VESTIGE, AND SOFT FLASH THAT DO NOT AFFECT THE FIT, FORM, OR FUNCTION OF THE PART ARE PERMISSIBLE PER DPNP-4.7-CS-01.
- WHEN DESIGNING A PART TO MATE TO THIS WEATHER PACK CONNECTOR, REQUEST THE LATEST COPY OF DRAWING NUMBER 12020084 FROM THE PACKARD ELECTRIC DIVISION.

DATE	SYM	REVISION RECORD	AUTHORITY	DR	CK
05FE90		ALL PARTS-REDRAWN FROM SEPARATE			
		'C' SIZE DWGS, REVISED TERMINAL			
		NOTE: 12040691-REMOVED 'PATENT			
		PENDING'-REV. LEVELS REMAIN THE SAME	133282	JC	JC
23MR90		ALL PARTS - ADDED NOTE *6 - NO REV.			
		UPDATE REQ'D.	133282	JC	JC
010C90		ALL PARTS - ADDED STANDARD			
		DESCRIPTION TO CHART, REVISED NAME			
		NO REV UPDATE REQ'D	136078	GC	GC
07JN91		12040691 - ADDED SIR TO APPLICATION			
		ADDED INDEX CODE NOTE & REVISED DIMS			
		3 PLCS - NO REV UPDATE REQ'D	142370	TS	
18JA10	05	12040691 - OBSOLETE	408718	FRE	RHG

PART NO.  
**1210 3348**

PACKARD ELECTRIC DIVISION  
GENERAL MOTORS CORPORATION  
WARREN, OHIO

37

PART NUMBER	REV	STATUS	CONNECTOR BODY	STANDARD DESCRIPTION	APPLICATION	REFERENCE TERMINAL/GENDER	MATING CONN.
12040691	A1	OBSOLETE	12040686	ASM CONN 3F W/P TWR	SIR IN-LINE	12089188-FEMALE	
12020737	A	-	12020731	ASM CONN 3M W/P TWR	DEVICE	12089040-MALE	DEVICE
12015800	A	-	12015790	ASM CONN 3F W/P TWR	IN-LINE	12089188-FEMALE	12015460
12015793	A	-	12015783	ASM CONN 3F W/P TWR	IN-LINE	12089188-FEMALE	12010717
12015610	A	OBSOLETE	12015459	ASM CONN 3M W/P TWR	DEVICE	12089040-MALE	DEVICE
12015382	A	OBSOLETE	12010716	ASM CONN 3M W/P TWR	DEVICE	12089040-MALE	DEVICE

PED / INTEGRAPH MICROSTATION		FILE SPEC: ***** *****	***** *****
THIRD ANGLE PROJECTION		METRIC DIMENSIONS ARE IN MILLIMETERS UNLESS OTHERWISE SPECIFIED.	
CODE NO.	6900	TOLERANCE UNLESS OTHERWISE SPECIFIED DECIMAL: ANGULAR ± 2	
Q.C.	-C-5110	ONE PLACE ± 0.3 TWO PLACE ± 0.15	
DWG. DATE	07FE90	SCALE	2:1
EST. NO.		DR. J. COLDSNOW	07FE90
REFERENCE NO.		APPR. A.R. HERMANN	DATE 07FE90
MATERIAL SPEC.		SEE DRAWING	
NAME TAXI ASM CONN 3 W/P TWR			
PART NO.	1210 3348		SIZE C