

Montageanweisung Kontaktbestückung Kompaktstecker 1 und 1.1
Mounting-Instruction Contact tooling compact plug 1 and 1.1



K3-MK/SVT2 01.99 Y 928 P00 222

1. Kontakt stecken, bis zum Klick! / Push, till Click!



2. Zug-Test / Pull-Test

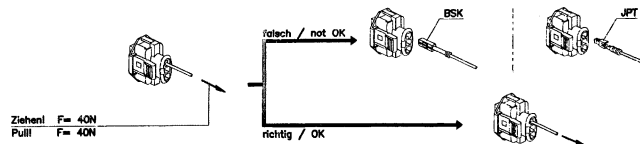

3. Verschließen unbestückter Kammern / Closing unused chambers

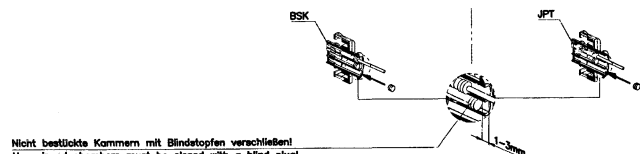

4. Push-back Prüfung nach Y 928 H00 210. Gilt nur für Kompakt 1.1
 Push-back check according to Y 928 H00 210. Only for compact 1.1

5. Elektrische Endprüfung nach Y 928 P00 153
 Final electrical check according to Y 928 P00 153

6. Ansetzen des Demontagewerkzeugs / Insert the disassembly tool

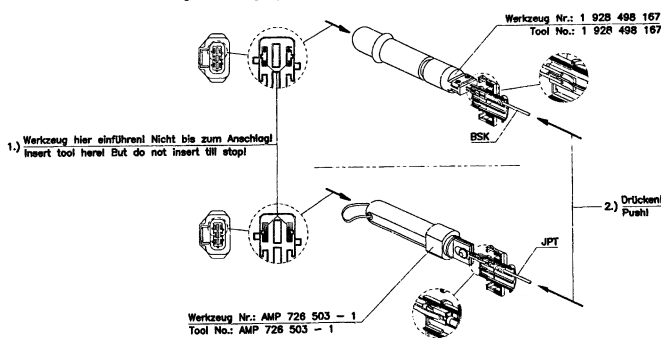

siehe Demontagvorschrift Y928 F00 071 für BSK-Kontakt / according to disassembly-instruction Y 928 F00 071 for BSK-contact

7. Entriegeln des Kontaktes / Unlocking the contact

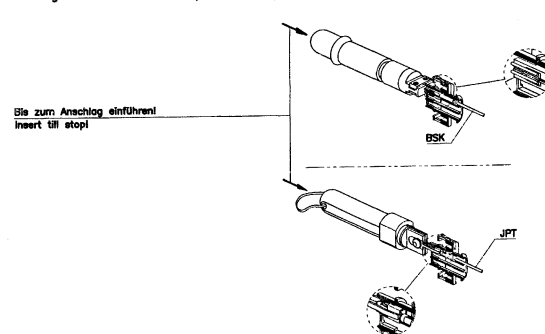

siehe Demontagvorschrift Y928 F00 071 für BSK-Kontakt / according to disassembly-instruction Y 928 F00 071 for BSK-contact

8. Herausziehen des Kontaktes / Pulling out the contact

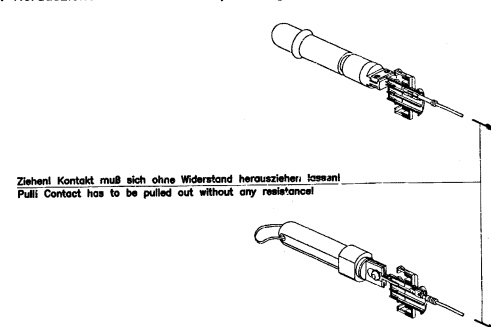

siehe Demontagvorschrift Y928 F00 071 für BSK-Kontakt / according to disassembly-instruction Y 928 F00 071 for BSK-contact

