

JFC

Jet Fuel Control type

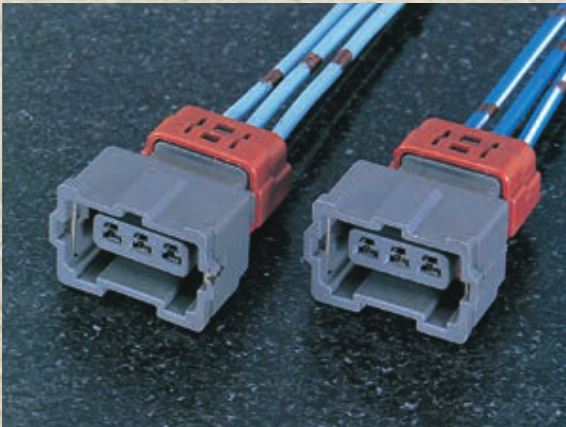

従来の防水コネクタに比べ、優れた防水性能を有し、特殊二重係止機構を採用した2.8mmタブサイズ（ピッチ：5.0）の電子燃料噴射装置用の小型多極防水コネクタです。

Improving on conventional sealed connectors, the JFC connector is a compact 2.8mm tab size (5.0mm pitch), multi-polar, sealed connector for attaching to electronic fuel injectors. The JFC connector employs a special dual-lock holding mechanism and offers excellent sealed performance.

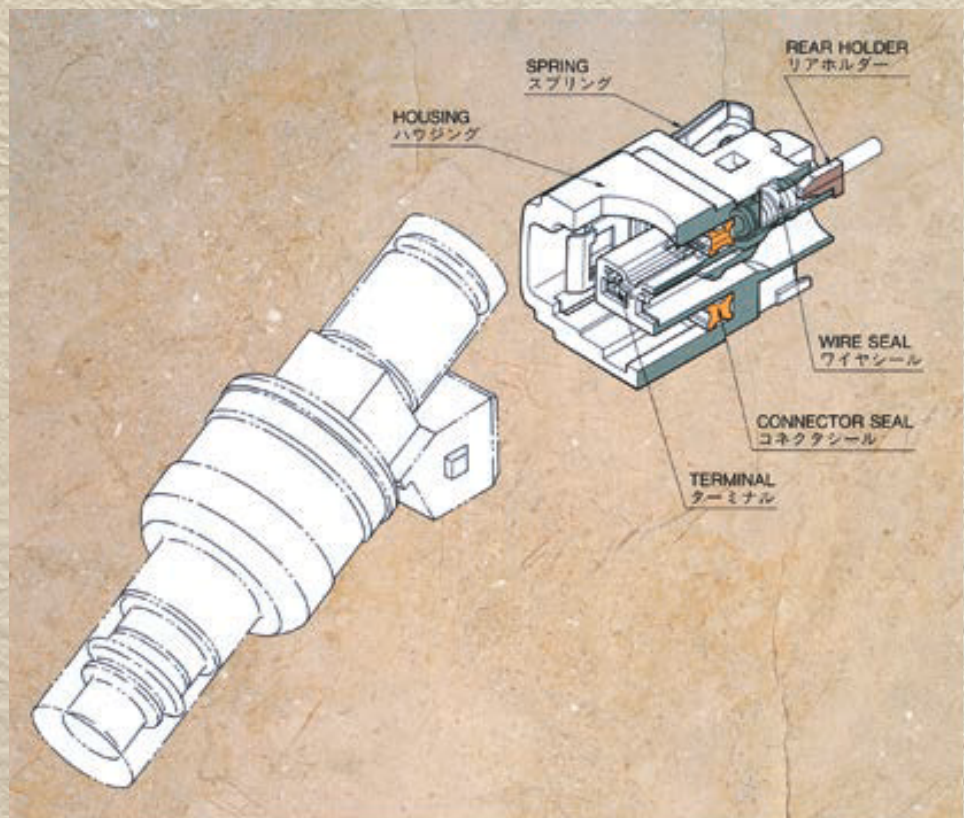

特長

JFCコネクタは、タブサイズ2.8mmの『電子燃料噴射装置用小型多極防水』コネクタです。最大極数6を有し、ハウジングロック機構には、スプリングロックを採用した事により、結合の信頼性を一段と向上させています。また、ワイヤシールの中央部にプラスチックを配置させた構造とする事で、特殊二重係止機構（スライド方式）を含めたリアホルダ構造を実現させ、端子の不完全挿入防止と、接続の信頼性、作業性を一段と向上させています。接触構造には信頼性の高いダブルカンチレバー機構を採用し、各極間には、独立型のシール構造を採用することにより優れた気密性を実現しています。

CHARACTERISTICS

The JFC connector is a **compact, multipolar sealed connector** with 2.8mm tab size terminals for attaching to electronic fuel injectors. The largest connector is a 6 pole type. The housing lock structure employs a spring lock, which greatly improves connection reliability.

Also, the wire seal incorporates a plastic insert structure that, together with a special rear holder type dual-lock holding mechanism (slide system) prevents incomplete terminal insertion as well as upgrading contact reliability and workability.

A double cantilever type contact mechanism ensures high reliability, and an independent seal structure for each pole provides excellent air-tight integrity.

性能

- 1) 適用電線
AV, CAVS 0.3~1.25mm² (A.W.G.#16~22)
AVS, AVSS 0.3~2mm² (A.W.G.#14~22)
- 2) ハウジングロック強度
98 N以上
- 3) 許容電流
10 A (AVS1.25mm², 3/6極通電時)
- 4) 防水性
内・外圧 49kPa以上

SPECIFICATIONS

- 1) **Applicable wire types :**
AV, CAVS 0.3~1.25mm² (A.W.G.#16~22)
AVS, AVSS 0.3~2mm² (A.W.G.#14~22)
- 2) **Housing lock strength :**
At least 98N
- 3) **Permissible current :**
10A (AVS 1.25mm², when
3/6 poles conducting)
- 4) **Sealed capability :**
At least 49kPa
internal and external pressure.

端子 TERMINAL

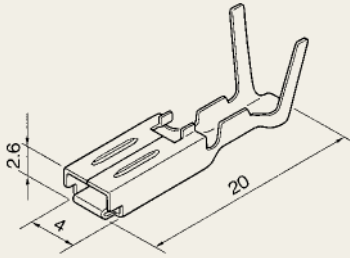
| 適用電線 WIRE SIZES | 端子名称 TERMINAL NAME | 形状 FORM | 部品番号 PART No. |
|--|-----------------------|--|------------------|
| AV, AVS 0.3~0.5 CAVS, AVf, AVX, AEX 0.5 | JFCF-0.3 |  | MT095-50030 |
| AV 0.85~1.25 AVf 0.75~1.25 AVS 0.85~2 CAVS, AVX, AEX 0.85~1.25 | JFCF-S | | MT095-50230 |
| AV, AVS, 0.3~0.5 CAVS, AVf, AVX, AEX 0.5 | JFCF-0.3-AU | | MT095-50060 |
| AV 0.85~1.25 AVf 0.75~1.25 AVS 0.85~2 CAVS, AVX, AEX 0.85~1.25 | JFCF-S-AU | | MT095-50260 |

ワイヤシール&プラグ WIRE SEAL & PLUG

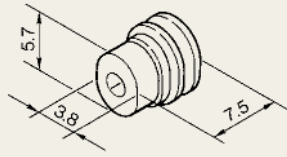
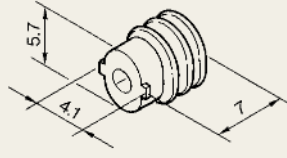
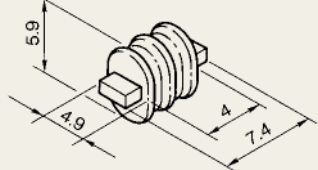
| 適用電線 WIRE SIZES | 名称 NAME | 形状 FORM | 部品番号 PART No. |
|--|-----------------|--|------------------|
| CAVUS 0.3~0.85 CAVS 0.3 | W/S JFC-R-1.1S |  | RS460-01601 |
| AV 0.3 AVS 0.3~0.5 CAVS 0.5~0.85 CAVUS 1.25 AVX, AEX 0.5 | W/S JFC-L-1.6S | | RS460-01701 |
| AV 0.5~0.85 AVf 0.5~0.75 AVS 0.85~1.25 CAVS 1.25 AVX, AEX 0.85 | W/S JFC-PU-2.1S | | RS460-01801 |
| AV, AVf, AVX, AEX 1.25 AVS 2 | W/S JFC-LG-2.6S |  | RS460-01300 |
| — | JFC PLUG |  | RS460-02000 |

端子 TERMINAL

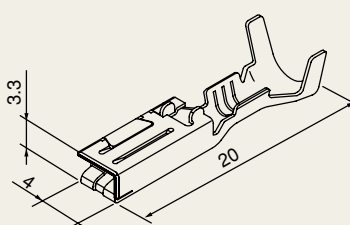
| 適用電線 WIRE SIZES | 端子名称 TERMINAL NAME | 形状 FORM | 部品番号 PART No. |
|--|-----------------------|--|------------------|
| AV, AVS 0.3~0.5 CAVS, AVf, AVX, AEX 0.5 | JFCHF-0.3 |  | MT095-52090 |
| AV 0.85~1.25 AVf 0.75~1.25 AVS 0.85~2 CAVS, AVX, AEX 0.85~1.25 | JFCHF-S | | MT095-52290 |
| AV, AVS 0.3~0.5 CAVS, AVf, AVX, AEX 0.5 | JFCHF-0.3-AU | | MT095-52060 |
| AV 0.85~1.25 AVf 0.75~1.25 AVS 0.85~2 CAVS, AVX, AEX 0.85~1.25 | JFCHF-S-AU | | MT095-52260 |

ワイヤーシール&プラグ WIRE SEAL & PLUG

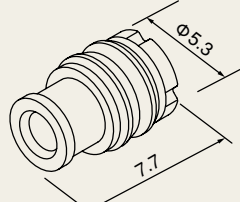
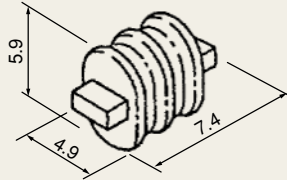
| 適用電線 WIRE SIZES | 端子名称 TERMINAL NAME | 形状 FORM | 部品番号 PART No. |
|---|-----------------------|--|------------------|
| CAVS 0.3 CAVUS 0.3~0.85 | W/S SRS-R-1.1S |  | RS610-06201 |
| AV 0.3, AVS 0.3~0.5 CAVS 0.5~0.85, AVX, AEX 0.5 CAVUS 1.25 | W/S SRS-L-1.6S | | RS610-07201 |
| AV 0.5~0.85 AVS 0.75f~1.25f CAVS, AVSS 1.25 | W/S SRS-PU-2.1S | | RS610-08201 |
| — | JFC PJUG |  | RS460-2000 |

TERMINAL, WIRE SEAL & PLUG PIN

ハウジング HOUSING

ハウジング HOUSING

2P

JFC02P-GY Ass'y
PB185-02326
JFC02P-B Ass'y
PB185-02026
JFC02P-L Ass'y
PB185-02046
JFC02P-BR Ass'y
PB185-02056
JFC02P-W Ass'y
PB185-02016
JFC02P-G Ass'y
PB185-02036

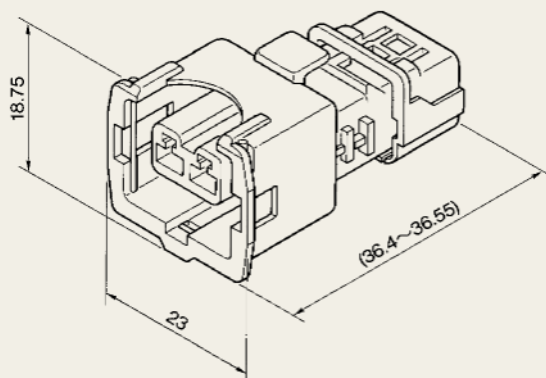

JFC02RP-GY Ass'y
PB186-02326
JFC02RP-SB Ass'y
PB186-02846
JFC02RP-DGY Ass'y
PB186-02926

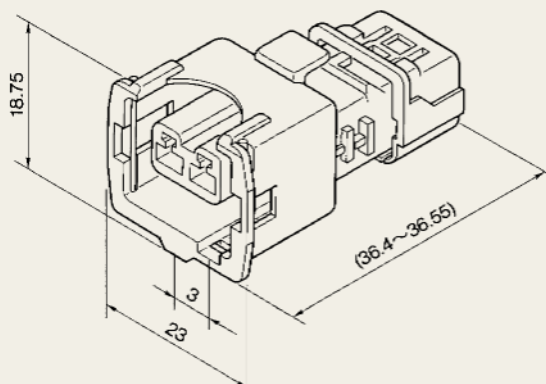

JFC02LP-GY Ass'y
PB187-02326
JFC02LP-G Ass'y
PB187-02036
JFC02LP-Y Ass'y
PB187-02876
JFC02LP-MB Ass'y
PB187-02246
JFC02LP-R Ass'y
PB187-02066
JFC02LP-LG Ass'y
PB187-02086

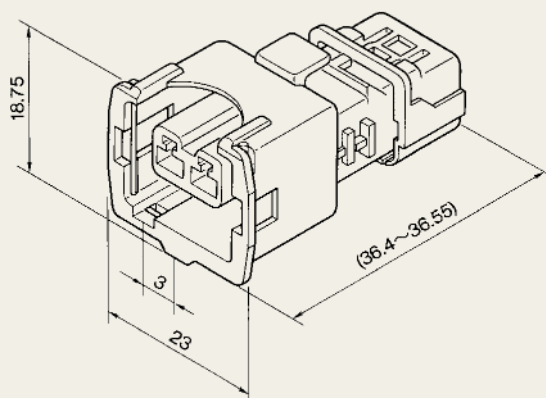

HOUSING

ハウジング HOUSING

2P

JFC02HRP-GY Ass'y
PB188-02326

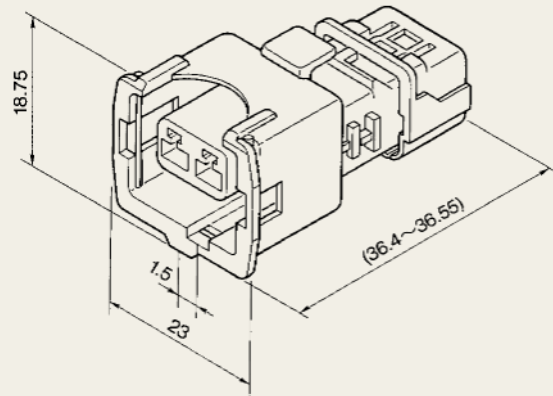

3P

JFC03P-GY Ass'y
PB185-03326
JFC03P-B Ass'y
PB185-03026

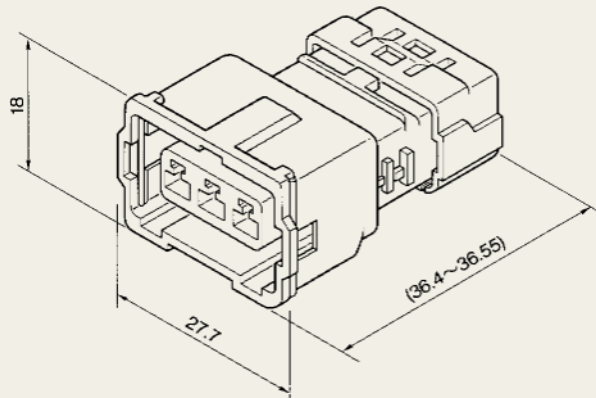

JFC03NP-W Ass'y
PB188-03016

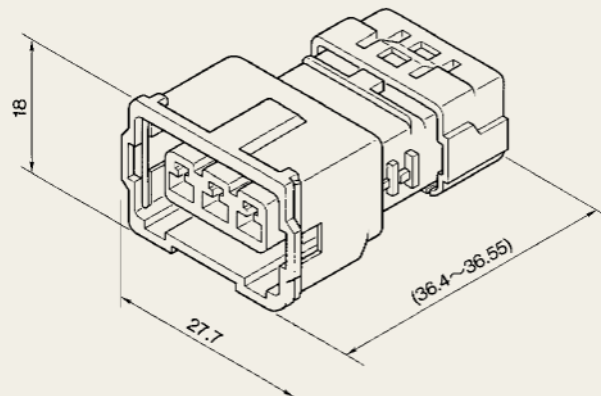

ハウジング HOUSING

4P

JFC04P-GY SA'Y
PB185-04326
JFC04P-B SA'Y
PB185-04026
JFC04P-L SA'Y
PB185-04046
JFC04P-BR SA'Y
PB185-04056

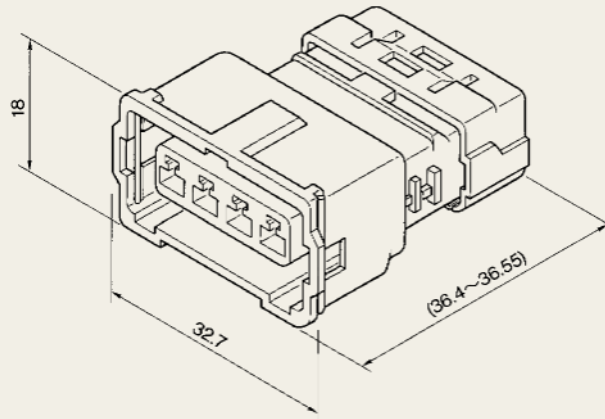

JFC04LP-DB SA'Y
PB187-04446

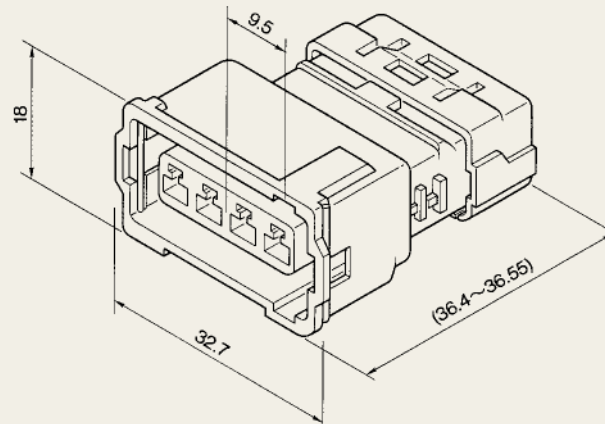

6P

JFC06P-GY SA'Y
PB185-06326
JFC06P-B SA'Y
PB185-06026
JFC06P-L SA'Y
PB185-06046
JFC06P-BR SA'Y
PB185-06056

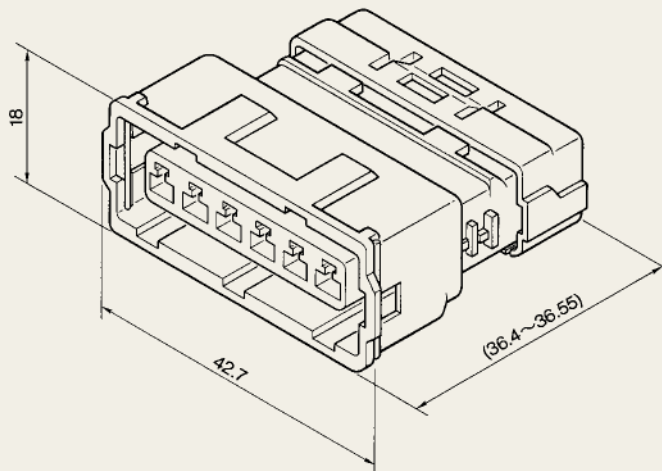

ハウジング HOUSING

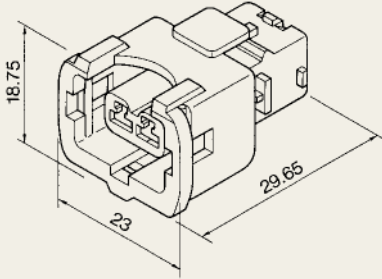
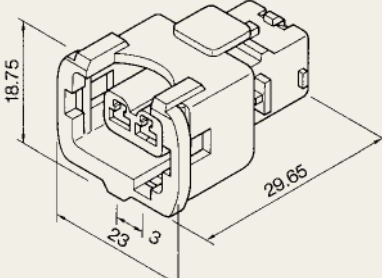
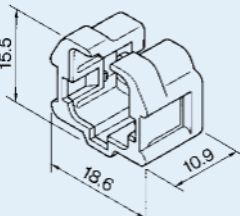
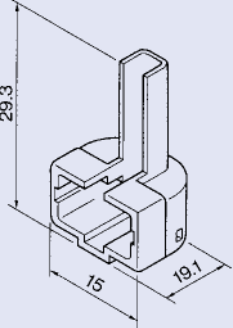
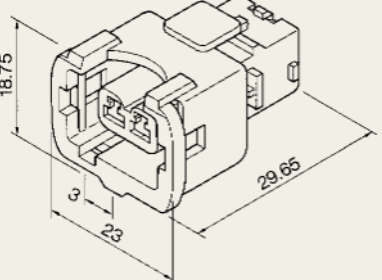
| | ハウジング HOUSING | リテーナー RETAINER | リアプロテクタ REAR PROTECTOR |
|----|---|--|---|
| 2P | <p>JFC02P-GY SA'Y PB185-02327 JFC02P-B SA'Y PB185-02027 JFC02P-L SA'Y PB185-02047 JFC02P-BR SA'Y PB185-02057</p>  | | |
| | <p>JFC02RP-GY SA'Y PB186-02327 JFC02RP-SB SA'Y PB186-02847</p>  | <p>R/H MJFC02P-BR PC025-02850</p>  | <p>R/P JFC02P-U PC020-02020</p>  |
| | <p>JFC02LP-GY SA'Y PB187-02327 JFC02LP-G SA'Y PB187-02037 JFC02LP-Y SA'Y PB187-02877 JFC02LP-MB SA'Y PB187-02247 JFC02LP-R SA'Y PB187-02067 JFC02LP-LG SA'Y PB187-02087</p>  | | |

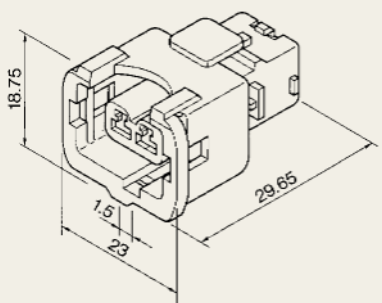
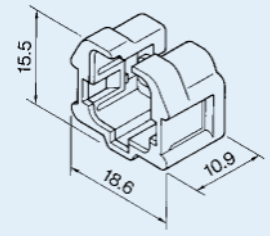
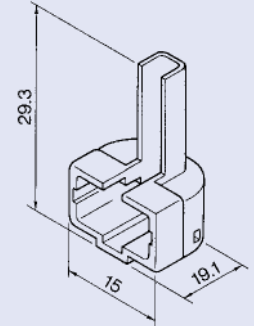
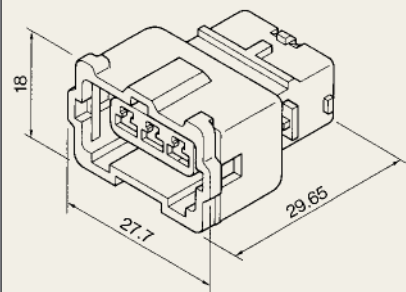
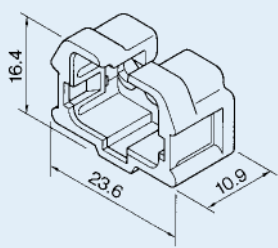
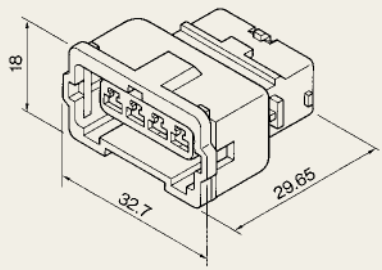
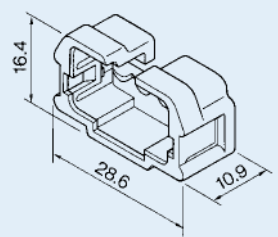
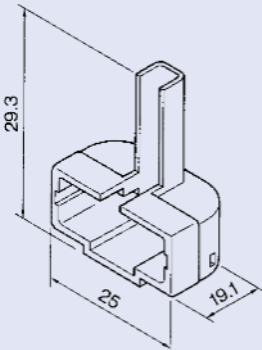
| | ハウジング HOUSING | リテーナー RETAINER | リアプロテクタ REAR PROTECTOR |
|-----------|--|---|--|
| 2P | <p>JFC02HRP-GY SA'Y PB188-02327 JFC02HRP-B SA'Y PB188-02027</p>  | <p>R/H MJFC02P-BR PC025-02850</p>  | <p>R/P JFC02P-U PC020-02020</p>  |
| 3P | <p>JFC03P-GY SA'Y PB185-03327 JFC03P-B SA'Y PB185-03027</p>  | <p>R/H MJFC03P-BR PC025-03850</p>  | |
| 4P | <p>JFC04P-GY SA'Y PB185-04327 JFC04P-B SA'Y PB185-04027 JFC04P-L SA'Y PB185-04047 JFC04P-BR SA'Y PB185-04057</p>  | <p>R/H MJFC04P-BR PC025-04850</p>  | <p>R/P JFC04P-U PC020-04020</p>  |

MJFC

HOUSING

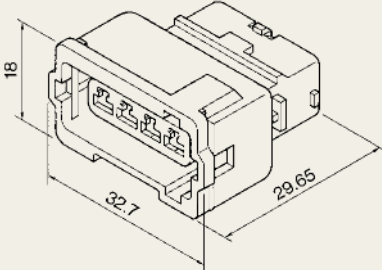
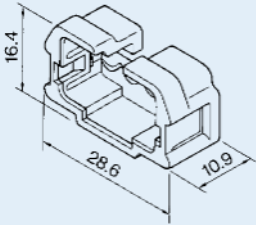
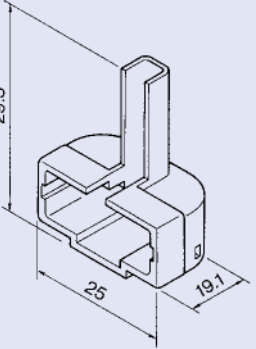
| | ハウジング HOUSING | リテーナー RETAINER | リアプロテクタ REAR PROTECTOR |
|-----------|--|--|---|
| 4P | JFC04LP-DB SA'Y PB187-04447  | R/H MJFC04P-BR PC025-04850  | R/P JFC04P-U PC020-04020  |