

Japan Aviation Electronics Ind., Ltd. CONNECTOR DIVISION	No.	J A H L - 1 7 2 8 - 4			PAGE 1/16	
TITLE MX23A Connector Handling Manual	REV	DATE	DCN No.	Chk.	Sup.	Mgr.
	1	05.May.27	—	T.HASEGAWA	<i>h.lin</i>	
ISSUED: 3RD ENGINEERING DEPARTMENT						
CONNECTOR DIVISION						

Contents

1. Scope	P.2
2. Applicable items	P.2
3. Crimping operation	P.2~P.9
3.1 Applicable wire	
3.2 Wire insulation stripping length	
3.3 Parts description	
3.4 Definition of "Good" product	
3.5 Definition of "Not Good" product	
4. Contact and dummy plug insertion method	P.10~P.11
4.1 Contact insertion method	
4.2 Dummy plug insertion method	
5. Front cap installation method	P.12
6. Front cap release method	P.13
7. Contact and dummy plug extraction method	P.14~P.15
7.1 Contact extraction method	
7.2 Dummy plug extraction method	
8. Cautions	P.16

1. Scope.

This manual covers how to handle MX23A connectors manufactured by JAE

2. Applicable items

Type	Name of product
Socket housing	MX23A**SF1
Front cap	MX23A**XF1
Socket contact	M23S05K351
	M23S05K4F1
Dummy plug	M120-55780

**described contact cavity number

3. Crimping operation

3.1 Applicable wire

Contact name	Applicable wire	Overall diameter
M23S05K351	1.25mm ² 0.85mm ² 0.5mm ²	φ 1.6~2.2mm (AVSS0.5mm ² ,0.85mm ² ,1.25mm ² equivalent)
M23S05K4F1	0.3mm ²	φ 1.4mm (AVSS0.3mm ² equivalent)

※ Recommendation: An appropriate wire should be used in its situation.

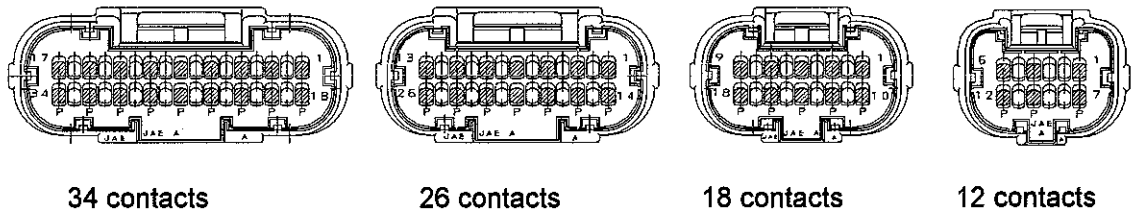

Fig.1 Socket housing insert the contact side

- contacts cavity applicable wire size →0.3~1.25mm²
- contacts cavity applicable wire size →0.3~0.85mm²

Table.1 . applicable wire size of contact cavity position

	■PART	□PART
AVSS0.3mm ²	○	○
AVSS0.5mm ²	○	○
AVSS0.85mm ²	○	○
AVSS1.25mm ²	○ (NOTE 1)	×
AVSSB0.5 mm ²	○	○
AVSSB0.75 mm ²	○	○
AVSSB1.25 mm ²	○ (NOTE 1)	×
AVS0.5f mm ²	○ (NOTE 1)	×
AVS0.75f mm ²	○ (NOTE 1)	×
AVSS0.3f mm ²	○	○

○ means: applicable

× means: not applicable

(NOTE 1) Reduction in the number of these wires is recommended. If increased the number of insertion these wires it way be hard to insert the contact into the Socket housing

3.2 Wire insulation stripping length

Make sure that the stripping length of wire shall be in the range as shown below. While stripping, check conductors and insulation for damage, missing and loose wire strands.

(Damaged wires, missing and loose wire strands are basically considered to be defective.)

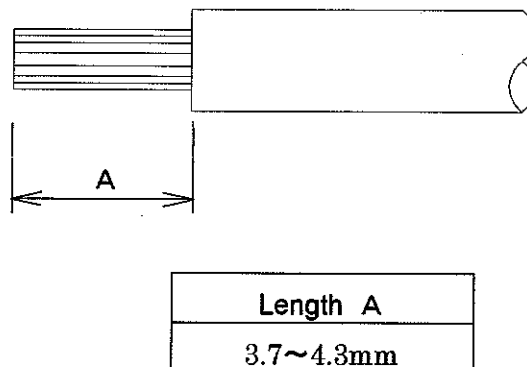

Fig.2 Wire insulation stripping length

Note:

- ◆ When this contact is crimping, place the wire inside the contact barrel in such a way that the wire insulation stripping length is inside the conductor barrel.

3.3 Parts description

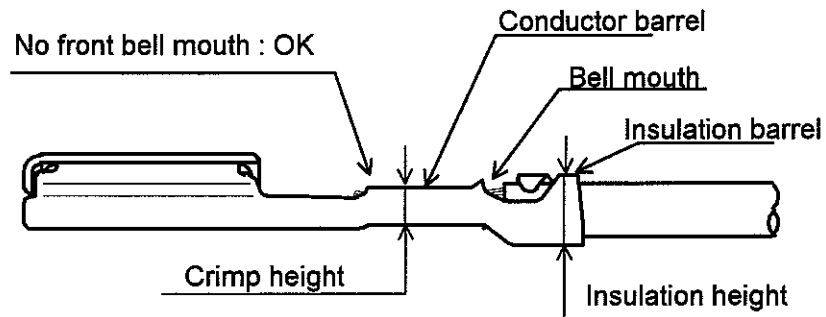

Fig.3 Parts description

3.4 Definition of "Good" product

The following diagram shows a contact that has been correctly crimping

- (1) Crimp height and crimp width (reference)
- (2) Described following tables Crimp height and crimp width (reference) application tools made by JAE

Table.1 Crimp height table

Socket contact	Applicable wire	Crimp height	Crimp width (reference)	Insulation height V/H(reference)	Insulation width : V/W (reference)
M23S05K351	AVSS0.5mm ²	1.075~1.175mm	2.00mm	2.00mm	2.0mm
	AVSS0.85mm ²	1.125~1.225mm	2.00mm	2.10mm	2.1mm
	AVSS1.25mm ²	1.225~1.325mm	2.00mm	2.30mm	2.15mm
	AVSSB0.5mm ²	1.075~1.175mm	1.99mm	1.96mm	2.00mm
	AVSSB0.75mm ²	1.125~1.225mm	2.04mm	2.40mm	2.10mm
	AVSSB1.25mm ²	1.225~1.325mm	2.03mm	2.64mm	2.25mm
	AVS0.5fmm ²	1.075~1.175mm	2.02mm	2.12mm	2.03mm
	AVS0.75fmm ²	1.125~1.225mm	2.04mm	2.40mm	2.15mm
M23S05K4F1	AVSS0.3mm ²	0.800~0.850mm	—	1.75mm	—

Note 1:

- ♦ The crimp width are reference value, when the respective crimp height is set.

Note 2:

- ♦ The crimp height, crimp width (reference) and the insulation height indicated in above are valid when JAE applicators are used.

Note 3:

- ♦ The insulation width (V/W) have priority over the insulation height (V/H).

Note 4:

◆ Measurement points in AVSS1.25mm² insulation crimping area

① Insulation width : V/W

Measure the width including the point illustrated with the arrows in Fig.4-1 by a measuring wide range tool like a vernier caliper

② Insulation height : V/H

Measure maximum position near the center of the crimping area (shown in Fig.4-2).

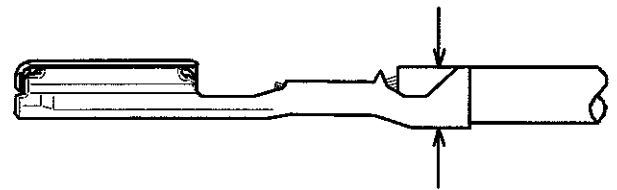
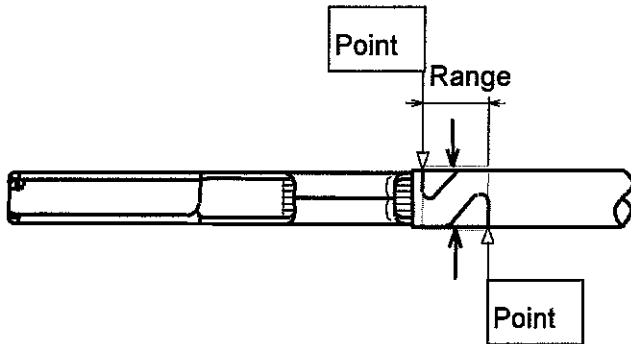
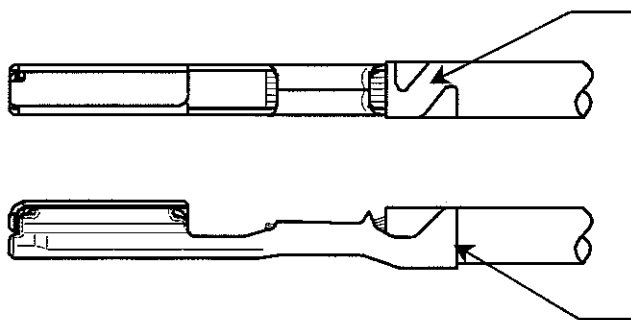

Fig.4-1 Measurement points in AVSS1.25mm² insulation crimping area (Insulation width: V/W)

Fig.4-2 Measurement points in AVSS1.25mm² insulation crimping area (Insulation height: V/H)

- (2) A back bell mouth (non-crimped wire portion) must be present. However, front bell mouth is not necessary.
- (3) The tip of the conductor must be exposed from the conductor barrel. However, the length of the exposed conductor is shorter than 0.5mm. Otherwise, the grommet rubber may be damaged when an irregular contact is inserted into the socket housing.
- (4) The conductor must not stick out from the conductor barrel.
- (5) The insulation must be wrapped inside the insulation barrel and must not intrude into the conductor barrel. However, see below because the shape of the wrapped insulation barrel is different with each applicable wire.



Both the insulation barrels don't wrap completely each other. But, there is no problem about the quality.

Both the insulation barrels lean slightly. If it isn't "Not Good" product as shown in Fig.16 (page 8), there is no problem about the quality.

Fig.5-1 The shape of the wrapped insulation barrel : AVSS1.25mm² (Ref.)

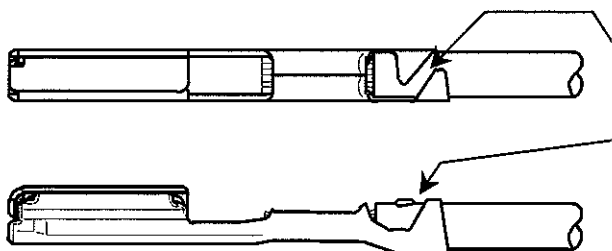

As compared with AVSS0.5mm², the insulation barrel is wrapped loosely in appearance. But, there is no problem about the quality.

Fig.5-2 The shape of the wrapped insulation barrel : AVSS0.85mm² (Ref.)

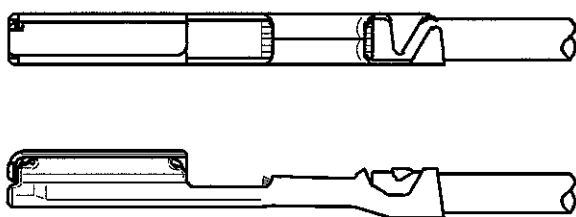

Fig.5-3 The shape of the wrapped insulation barrel : AVSS0.5mm² (Ref.)

- (6) No cracks or burrs are acceptable on the crimped area.
- (7) The wire insulation must not be damaged. If the wire insulation is damaged, the damage of the wire insulation has a bad influence on its sealing. The insulation barrel intrudes on the wire insulation, but the insulation barrel doesn't reach down to the wire conductor if it's "Good" product.

Applicable application tools by made by JAE

Contact type	Semi-automated applicator	Hand tool
M23S05K351 M23S05K3Q1	350-MX23-2	CT160-3-MX23
M23S05K4F1	350-MX23-2	—

Note: The tooth profile of M23S05K351 and M23S05K3Q1 is different from that of M23S05K4F1.

Note:

- ♦ If crimping of the insulation barrel is irregular, it can be hard to insert the contact into the socket housing because the insulation barrel can catch in the cavity of the rear cover. Therefore, verify that it is wrapped properly.

3.5 Definition of "Not Good" product

Do not use following incorrect crimping contact.

(1) Inserted wires too short

The conductor are not inserted far enough into the conductor barrel.



Fig. 6 Inserted wires too short

(2) Stripped insulation length too short

The insulation is inserted into the conductor barrel because the length of the stripped insulation is shorter than specified



Fig. 7 Stripped insulation length too short

(3) Extruded conductors

A piece of conductor is extruded from the barrel, or of the side of the contact.

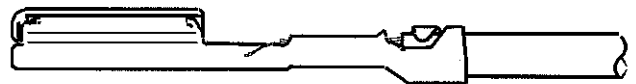
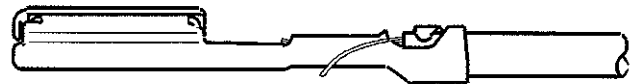

Fig. 8 Extruded conductors

(4) Stripped insulation length too long

The insulation is not inserted into the insulation barrel far enough because the length of the stripped insulation is longer than specified. "B" is less than 0.3mm in case of inserting the the insulation.

The conductor extend too far beyond the tip of the conductor barrel because the length of the stripped insulation longer than specified.

"C" is more than 0.5mm.

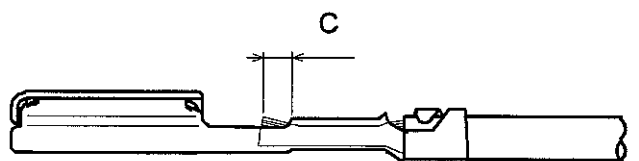
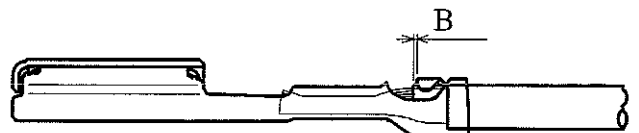

Fig.9 Stripped insulation length too long

(5) Bent contact

D

The mating portion of the contact is bent larger than 3 degrees (shown as "D") in either direction from the center line.

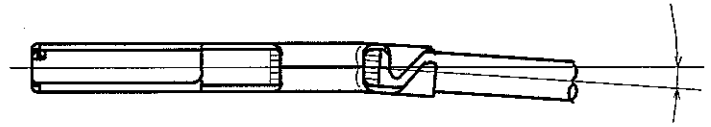

Fig. 10 Bent contact

(6) Twisted contact

The conductor barrel and the insulation barrel are twisted larger than 2.5 degrees (shown as "E") in either direction.

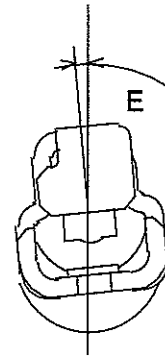

Fig. 11 Twisted contact

(7) Carrier strip cut burrs and back bell mouth

The carrier strip cut burr is larger than 0.2mm (shown as "F") and there is no back bell mouth.

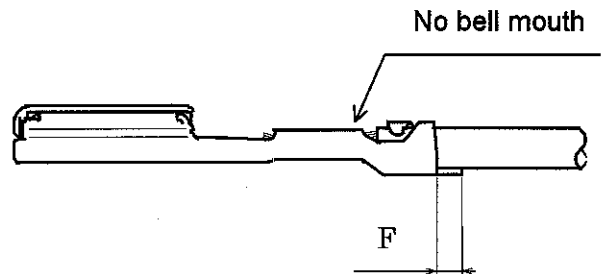

Fig. 12 Carrier strip cut burrs and bell mouth

(8) Bend-up, bend-down

The mating tip bent up or down compared to the conductor crimp area is

"H1">1°

"H2">1°

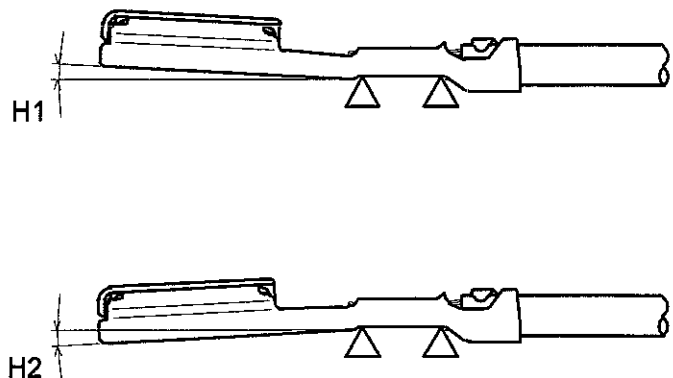

Fig. 13 Bend-up, bend-down

(9) Swollen the area of adjacent to conductor barrel

The area of adjacent to the conductor barrel is larger than 2.1mm (shown as "I")

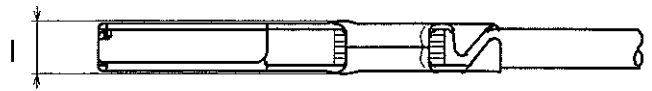

Fig. 14 Swollen the area of adjacent to conductor barrel

(1 0) Damaged insulation of wire

The insulation of wire is damaged in the area "J" shown in Fig. 15.

"J"=8.0mm

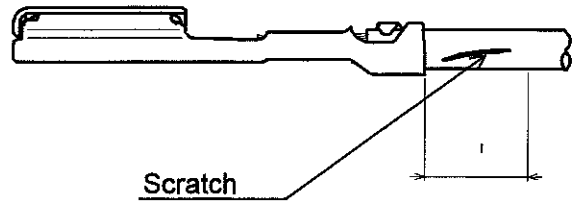

Fig. 15 Damaged insulation of wire

(1 1) Leaned insulation barrel

In the direction of illustration, lean of the insulation barrel is

"K" < 80°

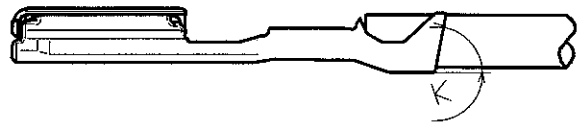

Fig. 16 Tilted insulation barrel

4. Contact and dummy plug insertion method

4.1 Contact insertion method

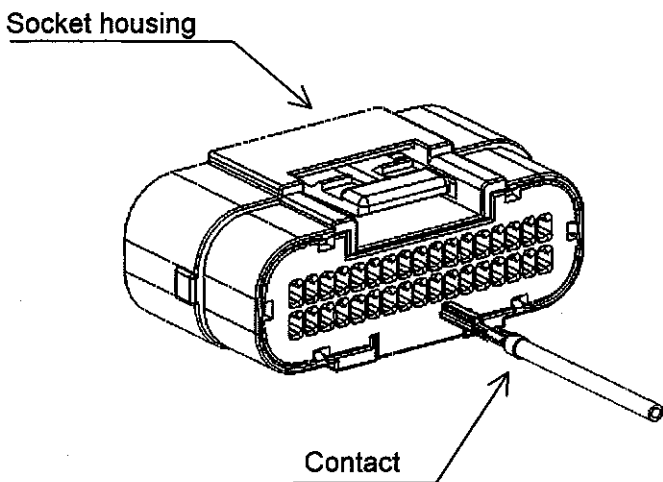

Fig17-1 Contact insertion method

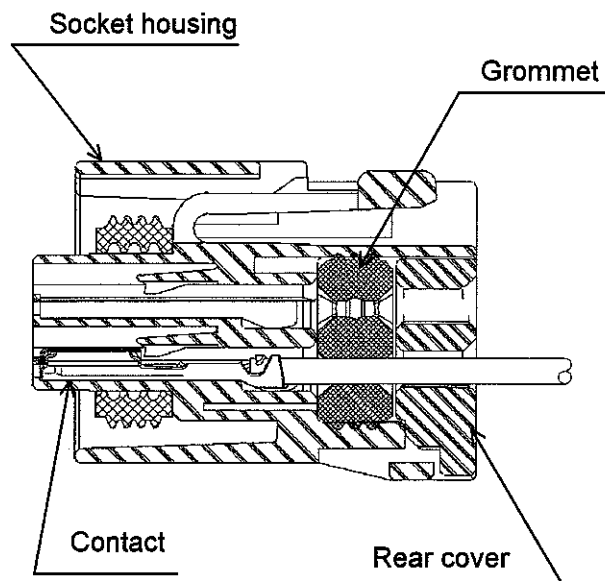

Fig17-2 Finished condition of contact insertion

After verifying that there are no scratches or foreign object on the contact and the direction of the contact, check the direction of contact and insert it into the socket housing through the cavity of the rear cover as shown in Fig.17-1, 2.

Insert the contact all the way into the bottom of the socket housing. After it is inserted, verify that the contact is locked by lightly (approx. 10N to 20N) pulling out the wire. At the time, do not pull it too hard. Contact lock may be damaged.

Reference:

♦If it is difficult for you to insert the contact, for example, contacts or dummy plugs are already inserted on both sides of it, you can insert the contact easily by inserting it at an angle as shown in Fig.18.

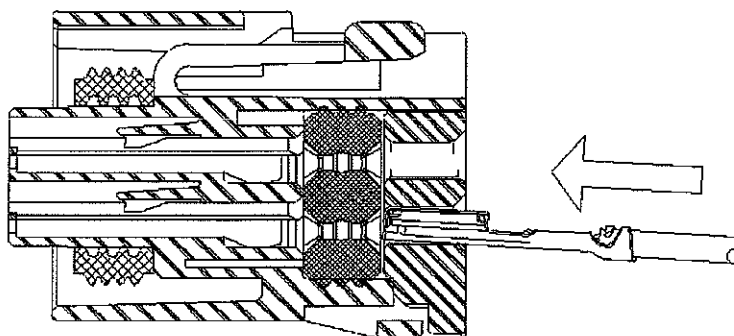

Fig.18 Contact insertion method (ref.)

Note:

♦You may insert or extract the same contact up to 3 times. However, if the contact applies to the regulations of item 3.5 "Definition of "Not Good" product", that contact must not be reused.

4.2 Dummy plug Insertion Method

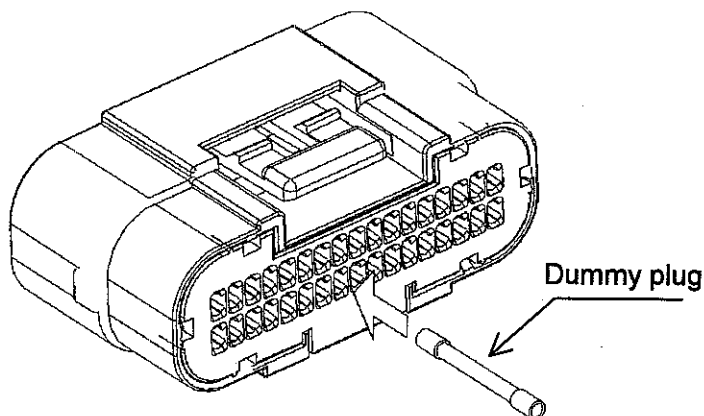

Fig.19 Dummy plug insertion method

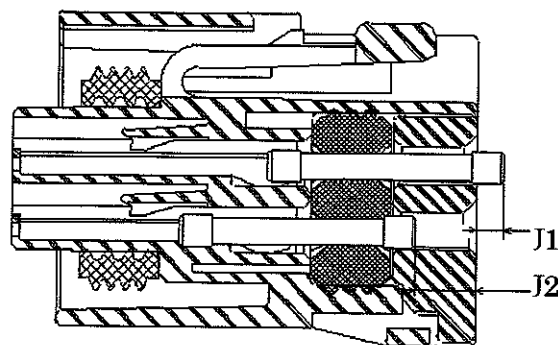

Fig.20 Inserted dummy plug

After verifying that there are no scratches or foreign object on the dummy plug and position the dummy plug parallel with the socket housing (Fig. 19), and insert it into the socket housing. When "J1" or "J2" shown in Fig. 20 satisfies the following criteria, the product after dummy plug insertion is acceptable.

$$\begin{aligned} J1 &< 1\text{mm} \\ J2 &< 1\text{mm} \end{aligned}$$

However, insert the dummy plug to the position that the edge of the socket housing corresponds with the edge of the dummy plug ($J1=J2=0$).

Note:

- ♦ There is not distinction of front and back in the dummy plug.

5 Front cap installation method

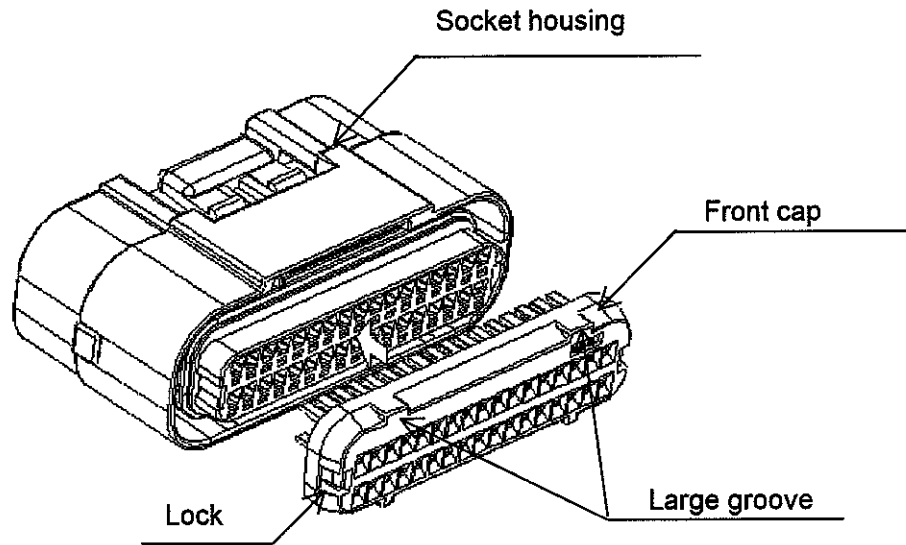

Fig.21 Front cap installation method

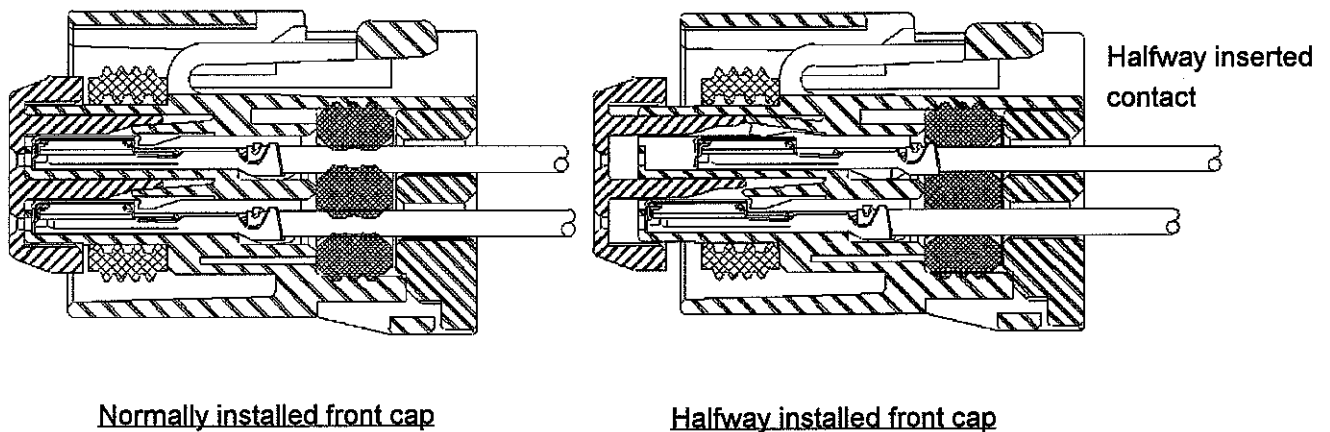

Fig.22 Front cap installation

Install a front cap after the contact insertion. Structurally, it is impossible to install the front cap after the contact insertion. Verify the vertical direction of the front cap during the front cap installation (Large groove; upside). When the front cap is assembled, put it in horizontally as shown in Fig. 21. If the front cap resists during the assembly, it may be due to the insufficient contact insertion shown in Fig. 22. Confirm that the contact is fully inserted. If it isn't fully inserted, insert it fully pursuant to item 4.1 "Contact insertion method". After the front cap is inserted all the way to the end, visually verify that the locks on both sides are on or lightly pull out the front cap (approx 10N to 20N) to see that the locks are activated.

Note:

- ◆ If the front cap is forcibly pressed in under a condition where the contact is only halfway inserted, both the socket housing and the front cap may be damaged, requiring subsequent replacement of both parts.

6. Front cap release method

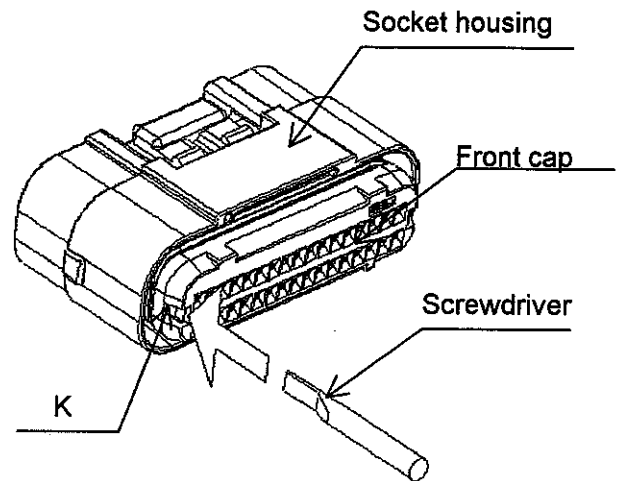
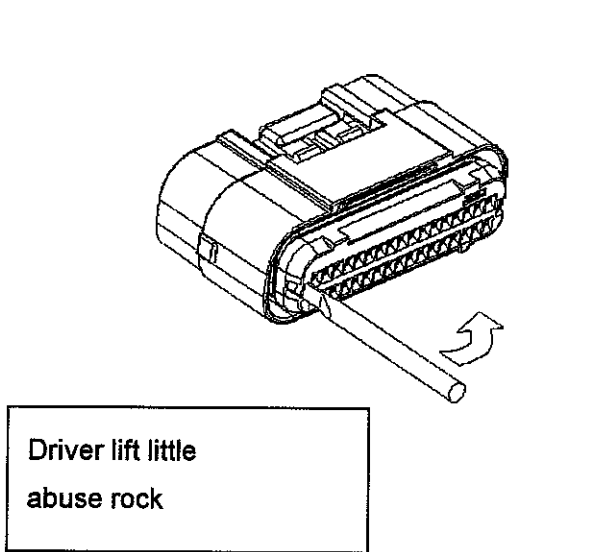

Fig.23 Front cap release method

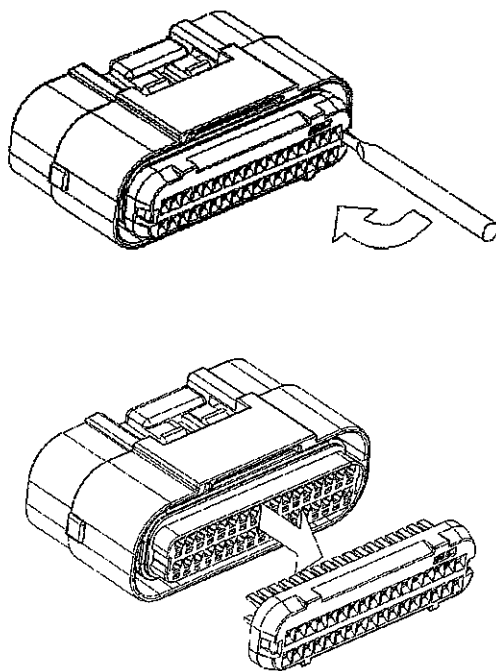

Fig.24 Front cap release method procedure

- ① Insert a precision screwdriver with a width of about 2mm into the gap of the lock "K" (on right or left sides) shown in Fig. 23, and lightly push in the tip.

Jiggle the driver and lift up the lock. While maintaining that condition, lightly pull out the front cap. The lock of the front cap will sit on the side of the socket housing.

- ② Remove the driver from the "k" portion and the other side lock released by the same method ①

(If use two drivers released both side locks at the same time)

- ③ Remove the driver from the "K" portion, and completely remove the front cap from the socket housing

Notes:

◆ You can release the front cap up to 3 times.

◆ Do not lift the lock too high with the driver. If the lock is lifted too high, it may be deformed or damaged. You can lift it up approx. 1mm.

◆ When you use a screwdriver, do not insert it into areas other than the "K" shown in Fig.23, and do not scratch both socket housing and contact.

◆ When you reuse the front cap, verify that the locks are intact and that there is no damage to the front cap. If the front cap is deformed or damaged, it needs to be replaced.

7. Contact and dummy plug extraction method

7.1 Contact extraction method

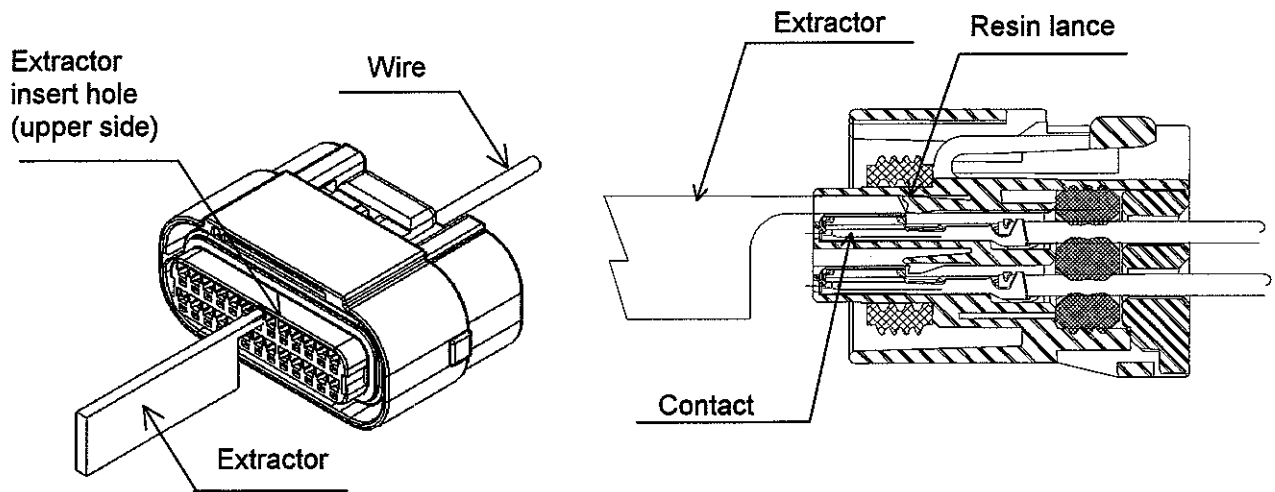

Fig.25 Contact extraction method

At first release the front cap. While holding the wire of the contact that needs to be extracted, push the contact lightly. Insert a contact extractor into the extractor hole of the housing in that condition. When the tip of the extractor touches the resin lance, jiggle the tip of the extractor to lift it up. While the tip of the extractor is lifting the resin lance, pull out the wire of the contact horizontally and lightly. At the time, pull the contact out slowly and horizontally. And don't jiggle the contact.

If you feel it is difficult to pull the contact when you are extracting the contact, it may be jiggled and caught on the grommet cavity or the rear cover. At worst, the grommet, the rear cover or the contact may be damaged. Instead, insert the contact for about 1mm and pull out the contact slowly and horizontally again, and do not extract the contact forcibly

JAE extractor	ET-MX23
---------------	---------

Notes:

- ♦Pull out the contact slowly and horizontally, and don't jiggle it. If it is pulled out forcibly, the grommet in the socket housing may be damaged and this damage may have a bad influence on its seal performance.
- ♦If the grommet rubber is damaged when the contact is pulled out, that socket housing must not be reused, and it must be changed for new socket housing. And verify the grommet by looking into the inside from the cavity of the rear cover without disassembling the housing.
- ♦You may insert or extract the same contact up to 3 times. However, if you find the contact to be defective per item 3.5 "Definition of "Not Good" product", that contact must not be reused.
- ♦Use the extractor by appropriate force so that the resin lance may be damaged.
- ♦Do not insert the extractor into areas other than the extractor hole. Also be very careful not to damage or deform the connectors (both housings and contacts)

7.2 Dummy plug extraction method

Use tweezers to hold the back of the dummy plug and extract the dummy plug from the back of the socket housing as shown in Fig.26. In the dummy plug extraction, do not damage the seal area of the dummy plug.

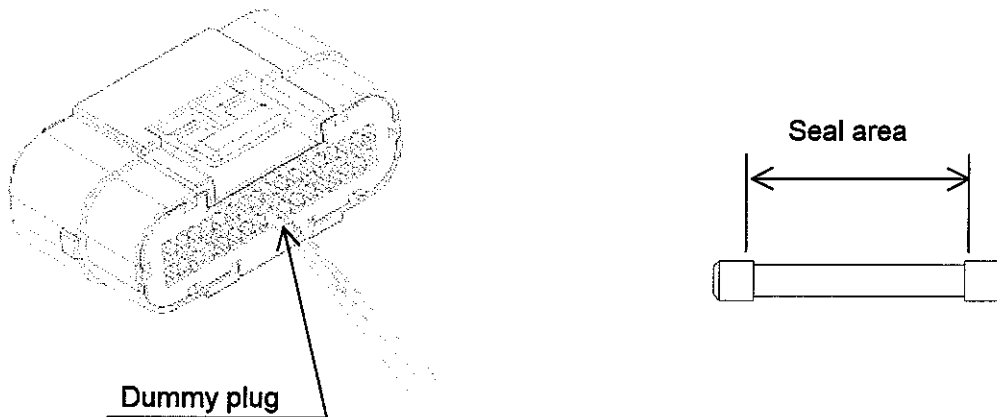

Fig.26 Dummy plug extraction method

You may extract the same dummy plug up to 3 times. However, if the extracted dummy plug is damaged, it must not be reused. If foreign object sticks to the dummy plug, use the dummy plug after cleaning the foreign object carefully.

If you insert the dummy plug all the way into the socket housing and can't extract the dummy plug as shown in Fig.26, it must be changed for a new socket housing. And you must not insert a pin etc. from the front of the socket housing to extract the dummy plug (see the figure below), because the insertion of the pin may damage the inside of the socket housing.

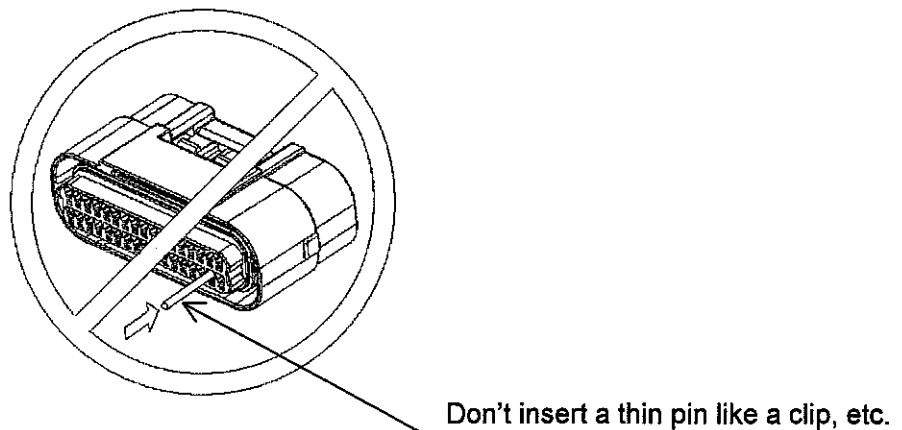

Fig.27 Don't insert a crimp front cavity

Notes:

♦When you extract the dummy plug, be careful not to damage the socket housing and the grommet rubber. If the socket housing and grommet are damaged, they must be changed for a new socket housing.

8. Cautions



CAUTION!

(Strictly observe the following rules to prevent injuries and damage to connectors.)

- Mate connectors in such a way that you hear a clicking sound.
- Be careful not to let the connector slip during insertion/extraction as your fingers hold it. Do not pull out the wires during extraction.
- Do not touch the pin contacts of the connector. Also do not let particles fall on the pin contacts.
- When you extract a contact from the connector, always use the designated fixture and tools.
- Be careful not to injure yourself while you are processing, soldering or crimping wires. Also, extra care is required to prevent connectors from being damaged.
- Do not disassemble the socket housing.
- Do not insert anything except a contact specified by this manual, because the grommet in the socket housing may be damaged.
- The seal ring in the socket housing must be handled carefully not to do damage.
- Always handle connectors and contacts according to this specification, and avoid unreasonable usage of the parts.