

PART NUMBER	REV	TERMINATOR	FEED TYPE	DESCRIPTION
1426581-1	A	LEADMAKER	MECH POST FEED	CUTS CARRIER
1426581-2	A	BENCH	MECH PRE FEED	CUTS CARRIER
1426581-6	A	LEADMAKER	MECH POST FEED	CONTINUOUS CARRIER
7-1426581-1	A	LEADMAKER	MECH POST FEED	-1 AND SPARE PARTS
7-1426581-2	A	BENCH	MECH PRE FEED	-2 AND SPARE PARTS
7-1426581-6	A	LEADMAKER	MECH POST FEED	-6 AND SPARE PARTS
7-1426581-7	A	-	-	SPARE PARTS KIT

WIRE	SIZE	TYPE	RANGE
WIRE	2.29 [1.090 IN]	F	0.75mm ² -2.00mm ²
INSUL	4.06 [1.160 IN]	F	1.90-2.70 [1.075-1.106 IN]

WIRE STRIP LENGTH	APPL INSTRUCTIONS
5.40-6.20 [1.212-.244 IN]	408-8322

TERMINAL APPL SPEC	FEED
-	14.10 [1.555 IN]

TYCO PN	MANUF'S PN
1572878-1	FS-FT-125

WIRE SIZE	CRIMP HEIGHT	PINPN & LENGTH [IN]
2.00mm ²	1.91 ±0.05 [1.075 ±.002 IN]	7-354778-9 [1.2890]
1.50mm ²	1.73 ±0.05 [1.068 ±.002 IN]	9-354778-5 [1.2970]
1.00mm ²	1.55 ±0.05 [1.061 ±.002 IN]	1-354779-1 [1.3045]
0.75mm ²	1.47 ±0.05 [1.058 ±.002 IN]	1-354779-8 [1.3080]

- △ RECOMMENDED SPARE PARTS.
- 2. GREASE RAM, CAM, CAM FOLLOWER AND FEED ROD LIGHTLY.
- △ CERTAIN TERMINALS REQUIRE LUBRICATION. REFER TO THE APPLICATOR INSTRUCTION SHEET FOR MORE INFORMATION.
- 4. LUBRICATE DAILY PER THE APPLICATOR INSTRUCTION SHEET SUPPLIED WITH THE APPLICATOR.
- △ ALL CRIMP DATA CALCULATED BY TYCO ELECTRONICS.
- △ WIRE DETAILS PROVIDED BY ORIGINAL CUSTOMER.

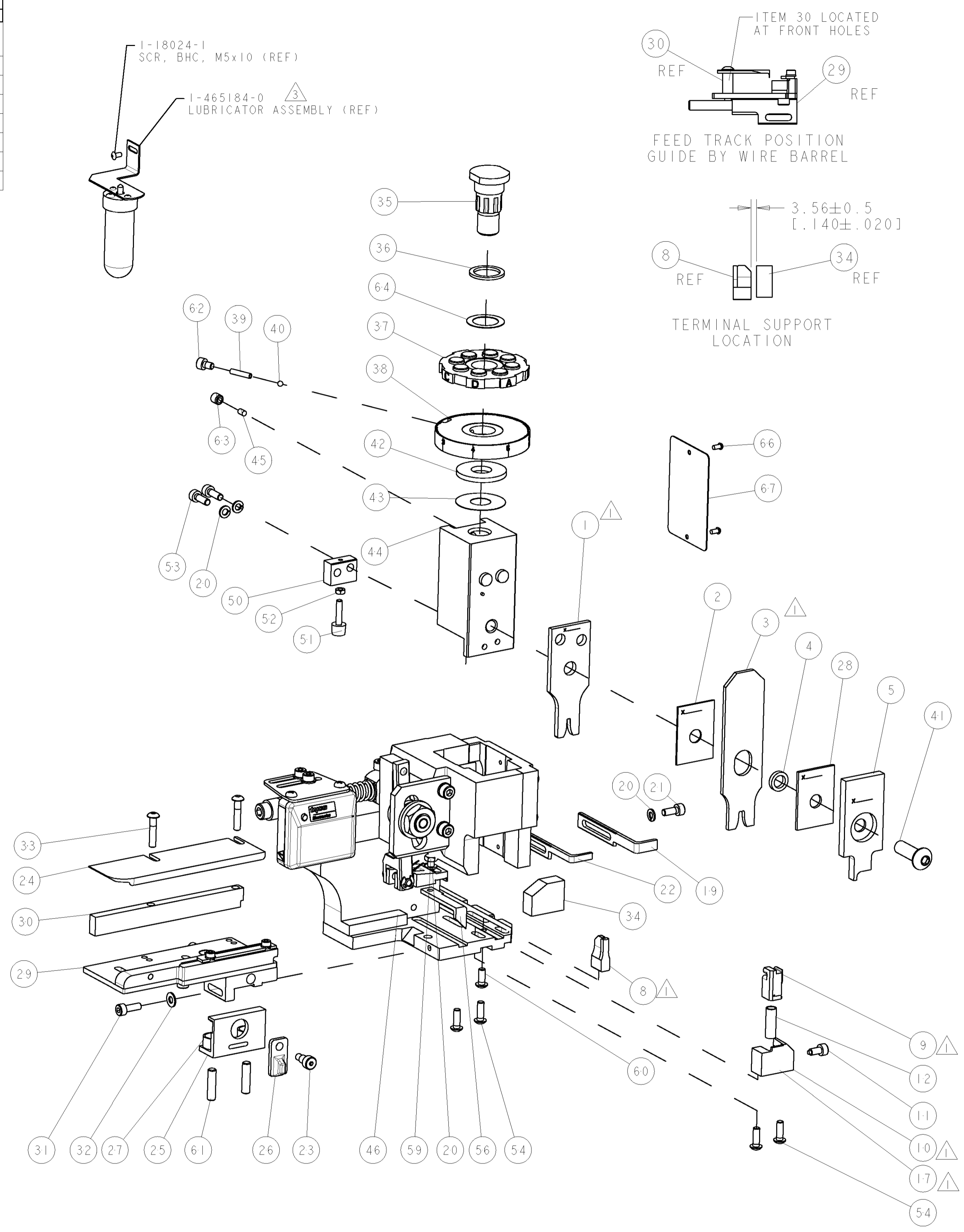
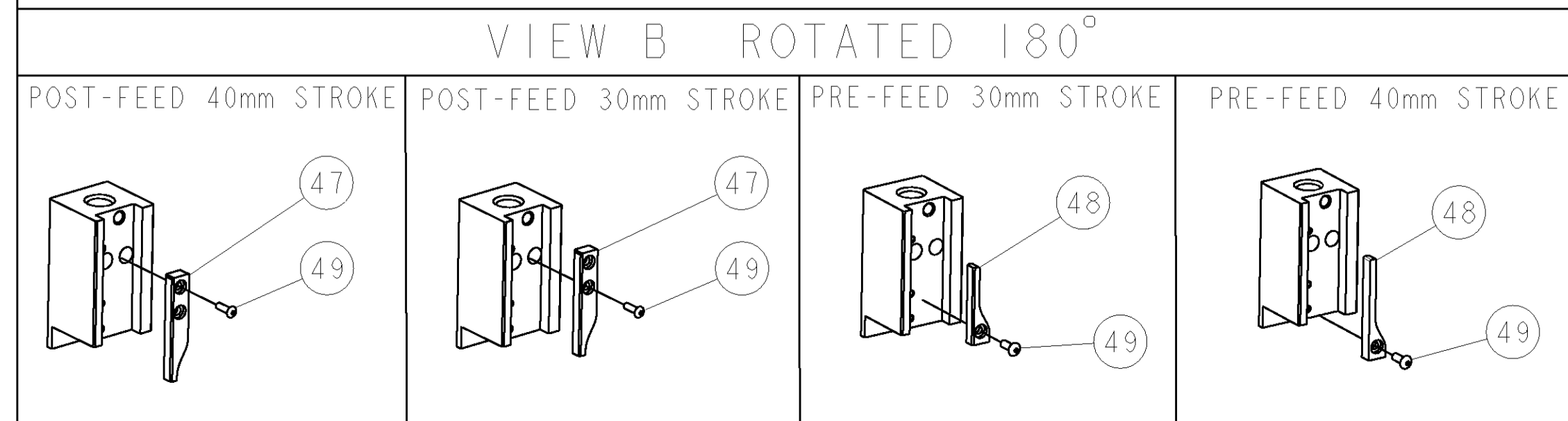

LOC	DIST	REV	DESCRIPTION	DATE	BY	APPD
A	66		SEE ECO-05-016405	20DEC2005	DP	MC

-	-	-	-	-	-	-	73	
-	-	-	-	-	-	-	72	
-	1	1	1	1	1	1338705-1	DOCUMENTATION PACKAGE	71
-	-	-	-	-	-	-	-	70
-	-	-	-	-	-	-	-	69
-	-	-	-	-	-	-	-	68
-	1	1	1	1	1	461264-1	PLATE, IDENTIFICATION	67
-	2	2	2	2	2	21017-2	SCREW, DRIVE	66
-	-	-	-	-	-	-	-	65
-	1	1	1	1	1	986950-1	WASHER, FLAT PRECISION	64
-	1	1	1	1	1	3-18031-0	SCR, SET, CUP POINT M6 X 6.0	63
-	1	1	1	1	1	18023-9	SCR, SKT HD CAP M4 X 6.0	62
-	2	2	2	2	2	2-18032-5	SCR, SET, FLT POINT M5 X 20.0	61
-	1	1	1	1	1	18024-7	SCR, BTN SKT HD CAP (M4 X 10.0)	60
-	1	1	1	1	1	5-18022-2	SCR, HEX HD CAP M4 X 8.0	59
-	-	-	-	-	-	-	-	58
-	-	-	-	-	-	-	-	57
-	1	1	1	1	1	1338685-1	PAWL, FEED	56
-	-	-	-	-	-	-	-	55
-	4	4	4	4	4	18024-8	SCR, BTN SKT HD CAP (M4 X 12.0)	54
-	2	2	2	2	2	1-18023-2	SCR, SKT HD CAP M4 X 12.0	53
-	1	1	1	1	1	18030-1	NUT, HEX, REG M3	52
-	1	1	1	1	1	811242-5	BUMPER, HOLD DOWN	51
-	1	1	1	1	1	690753-2	SPACER, TONKER	50
-	1	1	1	1	1	18024-3	SCR, BTN SKT HD CAP (M3 X 10.0)	49
-	-	-	-	-	-	1338675-1	CAM, UNIVERSAL PRE FEED	48
-	1	1	1	1	1	1338676-1	CAM, UNIVERSAL POST-FEED	47
-	1	1	1	1	1	1320999-3	APPLICATOR SUBASSEMBLY, HDI	46
-	1	1	1	1	1	690191-1	PLUG, NYLON	45
-	1	1	1	1	1	1338660-1	RAM	44
-	1	1	1	1	1	690125-1	SHIM SUB-ASSY	43
-	1	1	1	1	1	690124-1	WASHER, RAM (.115)	42
-	1	1	1	1	1	2-18024-6	SCR, BTN SKT HD CAP (M8 X 25.0)	41
-	1	1	1	1	1	23241-1	BALL, STEEL	40
-	1	1	1	1	1	2-22278-7	SPRING, COMPRESSION	39
-	1	1	1	1	1	1320922-1	DISC, ADJUST, INSULATION CRIMP	38
-	1	1	1	1	1	354777-1	WIRE DISC, ASSEMBLY	37
-	1	1	1	1	1	22480-5	SPRING, COMPRESSION	36
-	1	1	1	1	1	690212-1	POST, RAM	35
-	1	1	1	1	1	1320934-1	SUPPORT, TERMINAL	34
-	2	2	2	2	2	1-18024-0	SCR, BTN SKT HD CAP (M4 X 20.0)	33
-	1	1	1	1	1	18027-2	WASHER, FLAT, REG M4	32
-	1	1	1	1	1	1-18023-2	SCR, SKT HD CAP M4 X 12.0	31
-	1	1	1	1	1	1-1320908-5	SPACER, STRIP GUIDE	30
-	1	1	1	1	1	1633073-1	STRIP GUIDE ASSEMBLY	29
-	1	1	1	1	1	1-455888-5	SPACER, CRIMPER	28
-	2	2	2	2	2	1-22284-0	SPRING, COMPRESSION	27
-	1	1	1	1	1	356835-1	LEVER, DRAG RELEASE	26
-	1	1	1	1	1	240792-1	DRAG, TERMINAL	25
-	1	1	1	1	1	1320928-1	PLATE, STRIP GUIDE	24
-	1	1	1	1	1	980371-4	SCR, SKT HD SHLDR 5.0 DIA X 6.0	23
-	1	1	1	1	1	690472-2	STRIPPER	22
-	1	1	1	1	1	1-18023-1	SCR, SKT HD CAP M4 X 10.0	21
-	4	4	4	4	4	18025-2	WASHER, SPRG LOCK, REG M4	20
-	1	1	1	1	1	690472-1	STRIPPER	19
-	-	-	-	-	-	-	-	18
-	1	1	1	1	1	1338684-1	SHEAR HOLDER, FRONT	17
-	-	-	-	-	-	-	-	16
-	-	-	-	-	-	-	-	15
-	-	-	-	-	-	-	-	14
-	-	-	-	-	-	-	-	13
-	1	1	1	1	1	5-22280-0	SPRING, COMPRESSION	12
-	1	1	1	1	1	356885-4	STOP, SHEAR	11
-	1	1	1	1	1	1320921-1	SHEAR HOLDER, FRONT, CUT	10
-	1	1	1	1	1	454276-1	FLOATING SHEAR, FRONT	9
-	1	2	2	2	1	1633132-3	ANVIL, COMBINATION .090	8
-	-	-	-	-	-	-	-	7
-	-	-	-	-	-	-	-	6
-	1	1	1	1	1	3-455889-6	DEPRESSOR, SHEAR	5
-	1	1	1	1	1	238011-4	BLOCK, CRIMPER SPACER	4
-	1	2	2	2	1	7-456134-5	CRIMPER, INSULATION F PREMIUM	3
-	1	1	1	1	1	455888-8	SPACER, CRIMPER	2
-	1	2	2	2	1	2-456406-2	CRIMPER, WIRE PREMIUM	1

-77	-76	-72	-71	-6	-2	-1	PART NO	DESCRIPTION	ITEM NO
-	-	-	-	-	-	-	-	-	84
-	-	-	-	-	-	-	-	-	83
-	-	-	-	-	-	-	-	-	82
-	-	-	-	-	-	-	-	-	81
-	-	-	-	-	-	-	-	-	80
-	-	-	-	-	-	-	-	-	79
-	-	-	-	-	-	-	-	-	78
-	-	-	-	-	-	-	-	-	77
-	-	-	-	-	-	-	-	-	76
-	-	-	-	-	-	-	-	-	75
-	-	-	-	-	-	-	-	-	74

LOC	DIST	REV	DESCRIPTION	DATE	BY	APPD
A	66		SEE ECO-05-016405	20DEC2005	DP	MC

TYCO ELECTRONICS	DATE	BY	APPD
17NOV2005	17NOV2005	M. CLIFFORD	

PRODUCT SPEC	APPLICATION SPEC	SIZE	CAGE CODE	DRAWING NO	RESTRICTED TO
-	See Table	A1	00779	1426581	-