

Figure 1

95-308

1. INTRODUCTION

This instruction sheet provides assembly procedures for the AMP* Automotive On-Board Diagnostic Connector shown in Figure 1. Read these instructions thoroughly before assembling connector.

NOTE

All measurements are in metric units [with U.S. customary units in brackets].

Reasons for reissue of this sheet are provided in Section 6, REVISION SUMMARY.

2. DESCRIPTION

This receptacle connector is designed to mate with a plug on a portable diagnostic tester. The connector will accept a maximum of 16 contacts. The contacts should be terminated to 18-22 AWG wire.

3. ASSEMBLY PROCEDURES

The Terminal Position Assurance (TPA) must be in the open, or as-shipped, position (see Figure 1), then proceed as follows:

1. Align a terminated contact with the appropriate circuit cavity in the connector (with contact legs in the appropriate position).
2. Push the contact straight into the cavity as far as it will go.
3. Pull back on the contact wire slightly to be sure it is locked in position.
4. After all required contacts have been inserted, close and lock the TPA by pushing it forward until it snaps into place. See Figure 2.

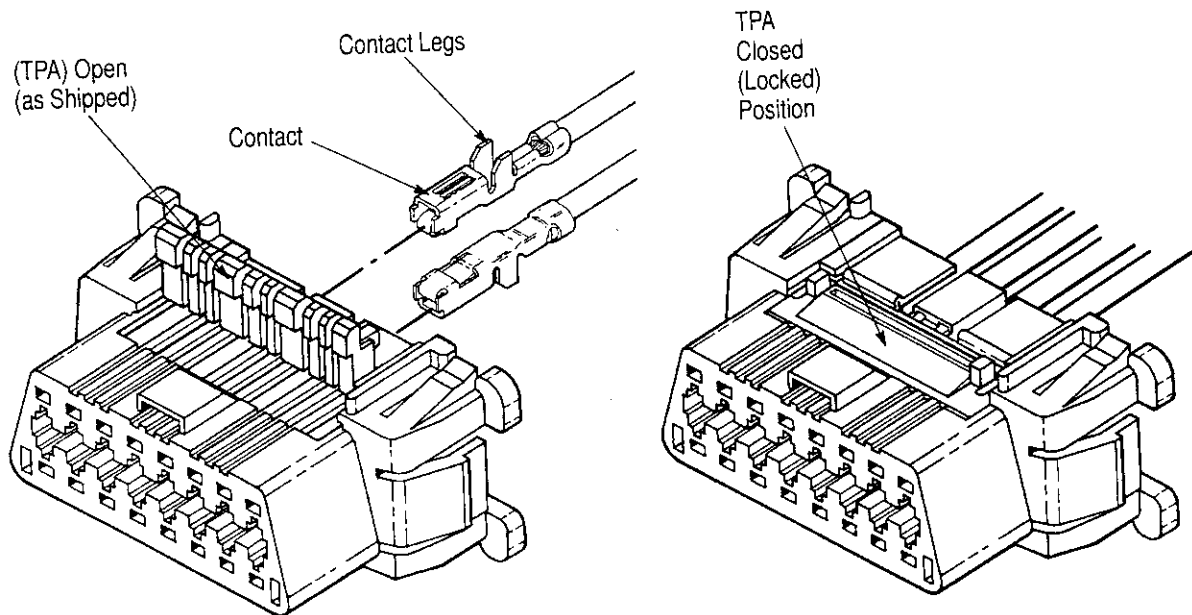

Figure 2

95-307, 95-308

4. CONTACT REMOVAL (See Figure 3)

1. Using a jeweler's screwdriver or similar tool, deflect the primary latch (found at the mating face of the connector) for that contact position. Do not put pressure on the wire until after the latch is deflected.
2. After deflecting the latch, pull lightly on the wire until the contact is released. Contact will back out approx. 2mm and stop.
3. Once the tip of the screwdriver is under the secondary lock finger, pry with the screwdriver slightly until the contact is released and can be pulled out with light tension on the wire. Do not force.

5. REVISION SUMMARY

Since the previous release of this instruction sheet, the following changes and additions were made:

Per EC 0780-0016-95

- Changed part number to 179631-1
- Changed art in Figures 1, 2, and 3
- Revised text in Sections 2, 3, 4, and 5

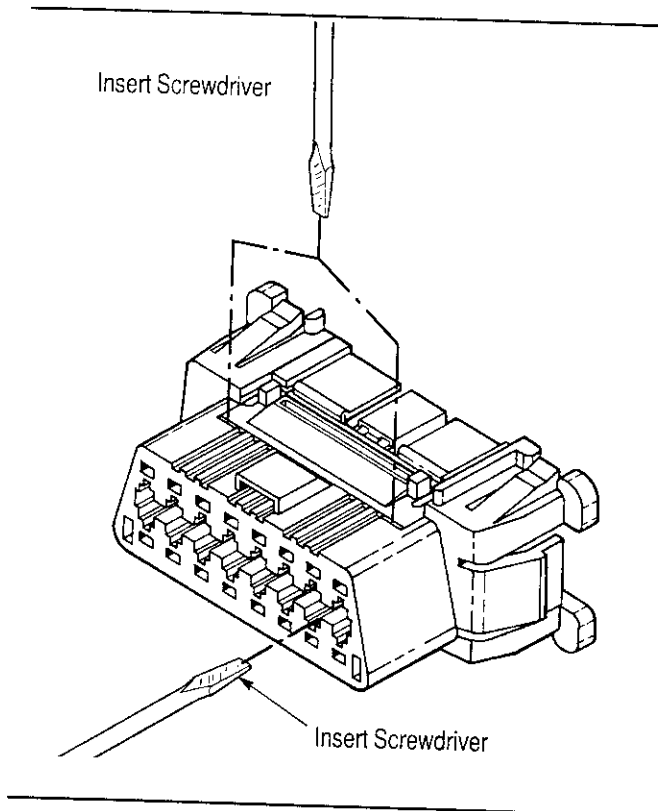

Figure 3

95-307